

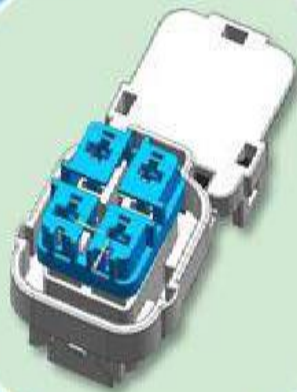

Ultra Wiring Connectivity System Ltd.

## ANNUAL REPORT 2022-23

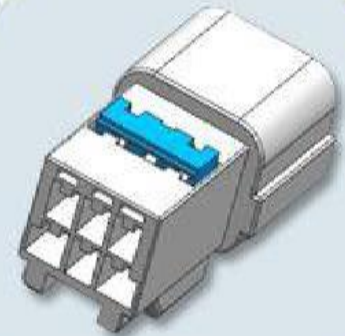
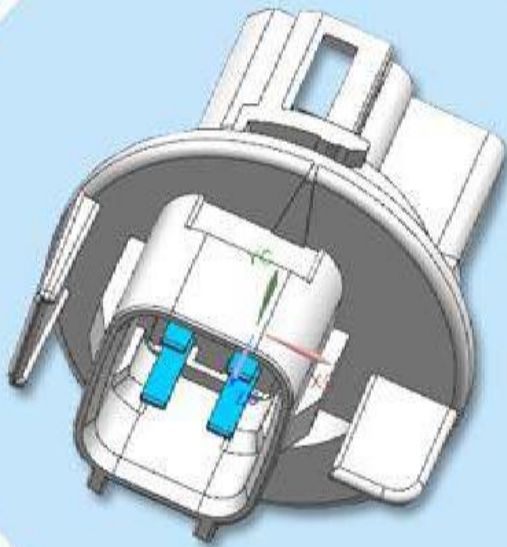

Manufacturers, Suppliers  
& Exporters of world-class  
Automotive Connectors, Bulb Holder,  
Cable Tie & Tie Clip

# ULTRA

## BLADE FUSES



Ultra Wiring Connectivity System Ltd. renowned name in manufacturing of automotive connectors, terminals and precision plastic components from the past 3 decades, have also set up the state-of-the art Blade Fuse manufacturing plant in India in the year 2014.

The plant is equipped with high speed & highly accurate hydro-pneumatic presses and fully automatic PLC Assembly machines. For the plastic housing, Company is already a pioneer in manufacturing plastic connectors and components for OEMs .

The company is equipped with in-house testing labs for all types of tests required for fuses as per (JASO standards), along with a strong R&D team lead by a highly experienced team of engineers.

### MINI BLADE FUSE



### STANDARD BLADE FUSE





# PASSENGER VEHICLE



## UNIVERSAL TYPE U-HOOK



- ▶ Aerodynamic design prevents wiper lifting during high-wind and high speed conditions
- ▶ Powder coated galvanized zinc steel frame reduces corrosion
- ▶ OE metal rail style refills
- ▶ Natural rubber squeeze for reduced noise and a clean, crisp wipe

### Sizes Available

SIZE	RUBBER WIDTH	TREATMENT
12"	6 MM	GRAPHITE COATED
13"	6 MM	GRAPHITE COATED
14"	6 MM	GRAPHITE COATED
15"	6 MM	GRAPHITE COATED
16"	6 MM	GRAPHITE COATED
17"	6 MM	GRAPHITE COATED
18"	6 MM	GRAPHITE COATED
19"	6 MM	GRAPHITE COATED
20"	6 MM	GRAPHITE COATED
21"	6 MM	GRAPHITE COATED
22"	6 MM	GRAPHITE COATED
24"	6 MM	GRAPHITE COATED
26"	6 MM	GRAPHITE COATED

# ULTRA

# COMMERCIAL VEHICLE



## ROD TYPE



- ▶ Aerodynamic design prevents wiper lifting during high-wind and high speed conditions
- ▶ Powder coated galvanized zinc steel frame reduces corrosion
- ▶ OE metal rail style refills
- ▶ Natural rubber squeeze for reduced noise and a clean, crisp wipe

### Sizes Available

SIZE	Rubber Width	Treatment
20"	8 MM	Graphite Coated
21"	8 MM	Graphite Coated
24"	8 MM	Graphite Coated
26"	8 MM	Graphite Coated



## BAYONETE TYPE



- ▶ Aerodynamic design prevents wiper lifting during high-wind and high speed conditions
- ▶ Powder coated galvanized zinc steel frame reduces corrosion
- ▶ OE metal rail style refills
- ▶ Natural rubber squeeze for reduced noise and a clean, crisp wipe

### Sizes Available

SIZE	Rubber Width	Treatment
14"	6 MM	Graphite Coated
15"	6 MM	Graphite Coated
17"	6 MM	Graphite Coated
20"	8 MM	Graphite Coated

# ULTRA



# BOLT TYPE



- ▶ Aerodynamic design prevents wiper lifting during high-wind and high speed conditions
- ▶ Powder coated galvanized zinc steel frame reduces corrosion
- ▶ OE metal rail style refills
- ▶ Natural rubber squeeze for reduced noise and a clean, crisp wipe

## Sizes Available

SIZE	Rubber Width	Treatment
20"	8 MM	Graphite Coated
21"	8 MM	Graphite Coated
22"	8 MM	Graphite Coated
24"	8 MM	Graphite Coated
26"	8 MM	Graphite Coated

# UNIVERSAL HOOK TYPE



- ▶ Aerodynamic design prevents wiper lifting during high-wind and high speed conditions
- ▶ Powder coated galvanized zinc steel frame reduces corrosion
- ▶ OE metal rail style refills
- ▶ Natural rubber squeeze for reduced noise and a clean, crisp wipe

## Sizes Available

SIZE	Rubber Width	Treatment
16"	6 MM	Graphite Coated
17"	6 MM	Graphite Coated
18"	6 MM	Graphite Coated
19"	6 MM	Graphite Coated
20"	8 MM	Graphite Coated
21"	8 MM	Graphite Coated
22"	8 MM	Graphite Coated
24"	8 MM	Graphite Coated
26"	8 MM	Graphite Coated
28"	8 MM	Graphite Coated

# ULTRA



U0124

C-250, 2 P M, JEY



U0126

C-250, 4 P M, SM

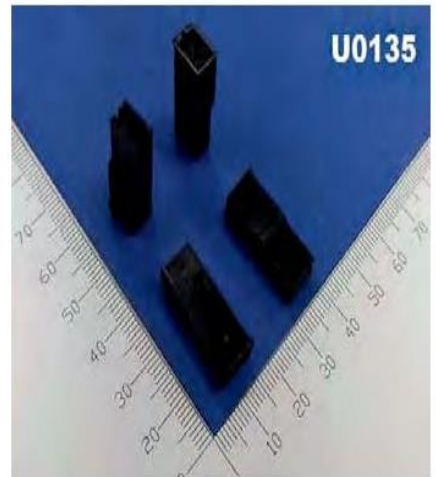

U0135

6.4 FEMALE CAP (Positive Lock)



U0101

[P-1] 1 P F, C-250



U0102

[P-2] 1 P M, C-250-1



U0103

[P-3] 2 P F, C-250



U0104

[P-4] 2 P F, C-250, Plain



U0105

[P-5] 2 P F, C-250 (Parallel)

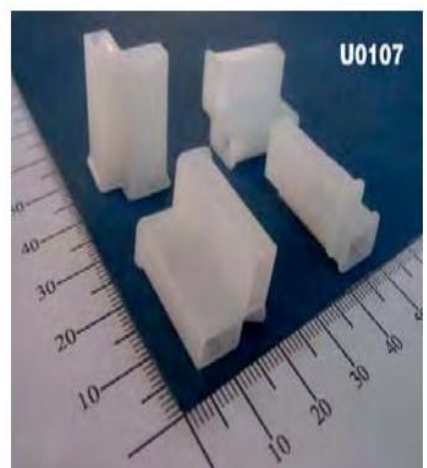

U0107

[P-7] 2 P L F, C-250, L-Type

**ULTRA**

## **CORPORATE INFORMATION**

### **BOARD OF DIRECTORS**

#### **NAME OF DIRECTORS**

MR. SANJAY MATHUR  
MRS. ARCHANA MATHUR  
MR. RAJINDARR AHUJA  
MR. ADITYA MATHUR

#### **DESIGNATION**

MANAGING DIRECTOR  
DIRECTOR  
INDEPENDENT DIRECTOR  
INDEPENDENT DIRECTOR

#### **CHIEF FINANCIAL OFFICER**

MR. PRABHAT BHATIA

#### **REGISTERED OFFICE/ MANUFACTURING UNIT I/II:**

PLOT 287 A&B SECTOR 59, HSIIDC INDL ESTATE,  
FARIDABAD, HARYANA- 121004

#### **COMPANY SECRETARY**

MRS. SARITA CHAURASIA

#### **MANUFACTURING UNIT III:**

PLOT NO- 300, SECTOR 68, IMT, FARIDABAD  
HARYANA, 121004.

#### **STATUTORY AUDITORS**

M/S. SANMARKS & ASSOCIATES

#### **REGISTRAR AND SHARE TRANSFER AGENT**

BIGSHARE SERVICES PRIVATE LIMITED,  
ADDRESS: 1ST FLOOR, BHARAT TIN WORKS  
BUILDING, OPP. VASANT OASIS APARTMENTS,  
MAROL MAROSHI ROAD, ANDHERI EAST,  
MUMBAI – 400059  
PHONE: 022 – 62638200

#### **BANKER**

HDFC BANK LIMITED

#### **SECRETARIAL AUDITORS**

M/S. ABHISHEK J & CO.

The logo for 'ULTRA' is displayed in a bold, italicized, orange font with a black outline, set against a black rectangular background.



## CHAIRMAN'S WORD

**Dear shareholders,**

I am elated to appear in front of you as the Managing Director of your Company and present to you the 18<sup>th</sup> Annual Report for the financial year 2022-23. I am obliged to you for your continued faith and confidence in your Company's abilities in its continuous journey of growth. I am filled with gratitude and a sense of accomplishment.

In the last financial year, India has arisen as the most robust and one of the fastest growing economies in the world despite significant challenges in the International environment – including continuing disruptions of supply chain following the rise in geopolitical tensions, the synchronized tightening of global monetary policies and inflationary pressures. India's economy bounced back after the pandemic in FY 2021-22 with the GDP growing of 7.2% in FY 2022-23. The Government of India continues to strengthen key sectors of the Indian economy with capex and policy initiatives to drive long-term sustainable growth. The fundamentals of the Indian economy remain strong.



### **Company Performance Review**

Our wiper business continued to witness high demand from the auto Industry backed by some of their investment proposals. We focus on delivering the highest quality of services to our clients drove us towards New Product Development, which consequently helped us in widening our product portfolio. UVS unmatched technological know-how and R&D capabilities played a pivotal role in such developments.

We hold the top-most position in the customized and complex blades and fuse manufacturing segment for the auto sector, which is a matter of great pride for us and stands testimony to our technological capabilities and manufacturing excellence.

Let me now move on your company's performance in financial year 2022-23. It has been a spectacular year of all round performances and achievements. We have achieved record sales and profits once again and we have made significant progress on several initiatives and projects including but not limited to wiper blades and fuse that we had set out to accomplish this year. Your company has performed commendably.

Allow me to outline the key results:

- Total turnover increased by 50.49% to Rs. 4443.89 Lacs.
- Profit before Tax (PBT) grew by 53.827% to Rs. 302.21 Lacs.

Currently, we at "UWS", have Three manufacturing locations equipped with latest technology to minimize energy consumption. We also plan to further increase the capacity in the coming years. Moreover, we are being cautious about our energy consumption and are relentlessly adopting energy-saving measures like efficient fixtures and equipment, minimum water discharge through recycling and much more for the healthy environment.

We are enough confident that with the sustained hard work of our dedicated employees, who have actively partnered us in our progressive journey and your continuous support, we will be succeeded in achieving our goal of enhancing growth and profitability on all fronts. Through relentless effort, "UWS" has been creating new benchmarks and this would have not been possible without your support. I express my gratitude to our bankers SIDBI and HDFC Bank for standing with us in thick and thin.

# ULTRA



I would like to extend my sincere gratitude to all those who contributed to our success. Together, we hope to achieve an even brighter future not only in the domestic market, but also in the overseas market.

With Best Regards

Sd/-  
Sanjay Mathur  
Chairman & Managing Director

**ULTRA**

## NOTICE

Notice is hereby given that the 18<sup>th</sup> Annual General Meeting ("AGM") of the members of Ultra Wiring Connectivity System Limited (the "Company") (Formerly known as Ultra Wiring Connectivity System Private Limited) will be held on Saturday, 30<sup>th</sup> September, 2023 at 11.30 A.M. at the Registered Office of the Company at Plot No.287, 287 A, 287 B, Sector-59 HSIIDC Incl. Estate, Ballabgarh, Faridabad, Haryana- 121004 to transact the following business:

### **ORDINARY BUSINESS:**

1. To receive, consider and adopt the Audited Financial Statements of the Company for the financial year ended March 31, 2023 along with the Reports of the Auditors' thereon.
2. To appoint a Director in place of Mr. Sanjay Mathur (DIN: 00285032), who retires by rotation and being eligible, offers himself for re-appointment.

### **SPECIAL BUSINESS:**

3. **To increase the remuneration of Mr. Sanjay Mathur (DIN-00285032), Managing Director of the Company**

To consider and, if thought fit to pass with or without modification(s), the following resolution as a Special Resolution:

**"RESOLVED THAT** pursuant to section 196, 197, 198 and 203 read with Schedule V of the Companies Act, 2013 together with the Companies (Appointment and Remuneration of Managerial Personnel) Rules, 2014 (including any statutory modification(s) or re-enactment thereof, for the time being in force) and subject to the Articles of Association and as per the recommendation of Audit committee and Nomination and Remuneration committee, the Board members hereby recommends to the shareholders for their approval in the ensuing AGM of the Company to increase the remuneration of Mr. Sanjay Mathur (DIN-00285032) - Managing Director of the Company and make the remuneration payment as per the revised terms and conditions of remuneration as set out below:

A. He will be designated as **Managing Director**.

B. Remuneration

- a) **Salary:** Current Salary of Rs.4,00,000 per month; The annual increments which will be effective 1st April each year, will be decided by the Board based on the recommendation of the Nomination and Remuneration Committee (hereinafter called the "NRC") and will be performance-based and take into account the Company's performance as well, within the said maximum amount.
- b) **Perquisites:** The Managing Director shall be entitled to the following perquisites classified into Categories 'A' & 'B':

#### **Category - A:**

- House Rent Allowance;
- House Maintenance;
- Station Allowance;
- Medical Reimbursement;
- Soft Furnishing;
- Provision for use of Company's car and fuel and other facilities/ reimbursements for official purpose which will not be considered as perquisites.

#### **Category - B:**

- Company's contribution to Provident Fund and Superannuation Fund or Annuity Fund shall not be included in the computation of the ceiling on perquisites to the extent these either singly or put together are not taxable under the provisions of the Income Tax Act;
- Gratuity as per Rules of the Company;
- Encashment of Leave, as per Rules of the Company.

C. **Functions**-He shall exercise duties and functions as may be delegated/ assigned to him by the Board of Directors/Committee of Directors from time to time.





- D. **Sitting Fee**-He shall not be paid any sitting fee for attending the Meeting of Board or Committee thereof.

**RESOLVED FURTHER THAT** the below remuneration will be payable to him as minimum remuneration in case of absence or inadequacy of profits in any financial year as permissible under Section II of Part II of Schedule V of the Companies Act, 2013 including such amendment(s), modification(s) and/or revision(s) as may be made by the Central Government in the said limits from time to time.

**RESOLVED FURTHER THAT** the Board of Directors be and is hereby authorized to revise, implement, alter and vary the terms and conditions of his appointment including remuneration in such manner as may be permitted in accordance with the provisions of the Companies Act, 2013 or any modification thereto and as may be agreed to by and between the Board and Mr. Sanjay Mathur and also to do and perform all such acts, deeds, matters and things as may be considered desirable or expedient to give effect to this resolution.

**RESOLVED FURTHER THAT** the Board be and is hereby authorized to take such steps as may be necessary for obtaining necessary approvals - statutory, contractual or otherwise, in relation to the above and to settle all matters arising out of and incidental thereto (if required) and to sign and execute deeds, applications, documents and writings that may be required, on behalf of the Company and generally to do all such other acts, deeds, matters and things as may be necessary, proper, expedient or incidental for giving effect to this Resolution.”

4. **To increase the remuneration of Mrs. Archana Mathur (DIN -00285041), Executive Director of the Company**

To consider and, if thought fit to pass with or without modification(s), the following resolution as a Special Resolution:

“**RESOLVED THAT** pursuant to section 196, 197, 198 and 203 read with Schedule V of the Companies Act, 2013 together with the Companies (Appointment and Remuneration of Managerial Personnel) Rules, 2014 (including any statutory modification(s) or re-enactment thereof, for the time being in force) and subject to the Articles of Association the committee and as per the recommendation of Audit committee and Nomination and Remuneration committee, the Board members hereby recommends to the shareholders for their approval in the ensuing AGM of the Company to increase the remuneration of Mrs. Archana Mathur (DIN 00285041) - Director of the Company and make the remuneration payment as per the revised terms and conditions of remuneration as set out below:

A. She will be designated as **Director**.

B. Remuneration

- a) **Salary:** Current Salary of Rs. 4,00,000 per month; The annual increments which will be effective 1st April each year, will be decided by the Board based on the recommendation of the Nomination and Remuneration Committee (hereinafter called the “NRC”) and will be performance-based and take into account the Company’s performance as well, within the said maximum amount.
- b) **Perquisites:** She will be entitled to the following perquisites classified into Categories 'A' & 'B':

**Category - A:**

- House Rent Allowance;
- House Maintenance;
- Station Allowance;
- Medical Reimbursement;
- Soft Furnishing;
- Provision for use of Company's car and fuel and other facilities/ reimbursements for official purpose which will not be considered as perquisites.

**Category - B:**



- Company's contribution to Provident Fund and Superannuation Fund or Annuity Fund shall not be included in the computation of the ceiling on perquisites to the extent these either singly or put together are not taxable under the provisions of the Income Tax Act;
  - Gratuity as per Rules of the Company;
  - Encashment of Leave, as per Rules of the Company.
- C. **Functions**-She shall exercise duties and functions as may be delegated/ assigned to her by the Board of Directors/Committee of Directors from time to time.
- D. **Sitting Fee**-She shall not be paid any sitting fee for attending the Meeting of Board or Committee thereof.

**RESOLVED FURTHER THAT** the below remuneration will be payable to her as minimum remuneration in case of absence or inadequacy of profits in any financial year as permissible under Section II of Part II of Schedule V of the Companies Act, 2013 including such amendment(s), modification(s) and/or revision(s) as may be made by the Central Government in the said limits from time to time.

**RESOLVED FURTHER THAT** the Board of Directors be and is hereby authorized to revise, implement, alter and vary the terms and conditions of his appointment including remuneration in such manner as may be permitted in accordance with the provisions of the Companies Act, 2013 or any modification thereto and as may be agreed to by and between the Board and Mrs. Archana Mathur and also to do and perform all such acts, deeds, matters and things as may be considered desirable or expedient to give effect to this resolution.

**RESOLVED FURTHER THAT** the Board be and is hereby authorized to take such steps as may be necessary for obtaining necessary approvals - statutory, contractual or otherwise, in relation to the above and to settle all matters arising out of and incidental thereto (if required) and to sign and execute deeds, applications, documents and writings that may be required, on behalf of the Company and generally to do all such other acts, deeds, matters and things as may be necessary, proper, expedient or incidental for giving effect to this Resolution.”

## 5. **Approval for Related Party Transaction**

To consider and, if thought fit to pass with or without modification(s), the following resolution as an Ordinary Resolution:

“**RESOLVED THAT** pursuant to the provisions of Section 188 of the Companies Act, 2013 (“Act”) and other applicable provisions, if any, read with Rule 15 of the Companies (Meetings of Board and its Powers) Rules, 2014, as amended till date, Regulation 23(4) of the Securities and Exchange Board of India (Listing Obligations and Disclosure Requirements) Regulations, 2015 (“Listing Regulations”) and the Company’s policy on Related Party transaction(s), approval of Shareholders be and is hereby accorded to the Board of Directors of the Company to enter into contract(s)/ arrangement(s)/ transaction(s) with certain persons, fall under the ambit of related parties within the meaning of Section 2(76) of the Act and Regulation 2(1)(zb) of the Listing Regulations on such terms and conditions as the Board of Directors may deem fit, up to a maximum aggregate value of Rs. 50 Lacs for the financial year 2023-24, provided that the said contract(s)/ arrangement(s)/ transaction(s) so carried out shall be at arm’s length basis and in the ordinary course of business of the Company.

**RESOLVED FURTHER THAT** the Board of Directors be and is hereby authorised to delegate all or any of the powers conferred on it by or under this resolution to Audit Committee of Directors of the Company and to do all acts and take such steps as may be considered necessary or expedient to give effect to the aforesaid resolution.”

By Order of the Board of Directors  
**Ultra Wiring Connectivity System Limited**

Sd/-  
**Sanjay Mathur**  
Chairman & Managing Director





Place:Faridabad  
Date: August 21, 2023

**Registered Office:**

Plot No.287, 287 A, 287B, Sector-59 HSIIDC Indl. Estate,  
Ballabgarh, Faridabad- 121004

**NOTES:**

1. The Explanatory Statement pursuant to Section 102 of the Companies Act, 2013, which sets out details relating to Special Business at the meeting, is annexed hereto.
2. **A member entitled to attend and vote is entitled to appoint a proxy to attend and vote on his/her behalf and the proxy need not be a member of the company.**
3. **Proxies, in order to be effective, should be duly stamped, completed, signed and deposited at the Registered Office of the Company not less than 48 hours before the meeting. Pursuant to Section 105 of the Companies Act, 2013, a person can act as proxy on behalf of not more than fifty members holding in aggregate, not more than ten percent of the total share capital of the Company. Members holding more than ten percent of the total share capital of the Company may appoint a single person as a proxy who shall not act as a proxy for any other member. A Proxy form is sent herewith. Proxies submitted on behalf of the companies, societies etc., must be supported by an appropriate resolution/authority, as applicable.**
4. The Register of Members and the Share Transfer Books of the Company will remain closed from Saturday, September 23, 2023 to Saturday, September 30, 2023 (both days inclusive).
5. The route map showing directions to reach the venue of the meeting is annexed.
6. Members/Proxies are requested to affix their signatures at the space provided on the attendance slip annexed to the proxy form and hand over the slip at the entrance of the meeting hall.
7. The members, holding shares in dematerialized form may intimate any change in their addresses or bank details/mandates to their Depository Participants (DP) immediately.
8. To prevent fraudulent transactions, members are advised to exercise due diligence and notify the Company of any change in address or demise of any member as soon as possible. Members are also advised not to leave their demat account(s) dormant for long. Periodic statement of holdings should be obtained from the concerned Depository Participant and holdings should be verified.
9. The Notice of Annual General Meeting, along with the Attendance Slip and Proxy Form, are being sent by electronic mode to all members whose email addresses are registered with the Company/Depository Participant(s) unless a member has requested for a hard copy of the same.
10. All documents referred to in the accompanying notice and the explanatory statement shall be open for inspection at the Registered Office of the Company between 10.00 a.m. to 05.00 p.m. on all working days, except on holidays, up to and including the date of the Annual General Meeting of the Company.
11. No physical Notice/Annual Report will be dispatched to Shareholders due to ongoing COVID pandemic. Circular issued by the Ministry of Corporate Affairs dated May 05, 2020 specifically mentions the same. Electronic copy of the Annual Report 2021-22 is being sent to those members whose email address is registered with the Company/ Depositories for communication purpose. Members may note that this Notice of AGM and Annual Report will also be available on the Company's website viz. [www.ultrawiring.com](http://www.ultrawiring.com)
12. To support the "Green Initiative", Members who have not registered their email addresses are requested to register the same with the Company's Registrar and Share Transfer Agent/their Depository Participants, in respect of shares held in physical / electronic mode, respectively. Copies of Annual Report will not be distributed to the members at the venue of the AGM.
13. Pursuant to the provisions of Section 108 of the Companies Act, 2013 read with Rule 20 of the Companies (Management and Administration) Rules, 2014 (as amended) and Regulation 44 of SEBI (Listing Obligations & Disclosure Requirements) Regulations 2015 (as amended), and the Circulars issued by the Ministry of Corporate Affairs, the Company is providing facility of remote e-voting to its Members in respect of the business to be transacted at the AGM. For this purpose, the Company has entered into an agreement with National Depository Services (India) Limited (NSDL) for facilitating voting through electronic means, as the authorized e-Voting's agency. The facility of casting votes by



a member using remote e-voting as well as venue voting system on the date of the AGM will be provided by NSDL.

14. The facility for voting, through polling paper shall also be made available at the AGM and the Members attending the meeting who have not already cast their vote by remote e-voting shall be able to exercise their right to vote at the AGM. Poll is conducted under the supervision of the Scrutinizer appointed for e-voting and poll. Scrutinizer decision on validity of vote will be final.

15. The Chairman shall at the meeting, at the end of discussion on the resolutions on which voting is to be held, allow voting with the assistance of Scrutinizer, by use of Polling Paper for all those members who are present at the meeting but have not cast their votes by availing the remote e-voting facility.

16. The Board of Directors of the Company has appointed M/s Abhishek J & Co., Practicing Company Secretaries as a Scrutinizer, for conducting voting and poll during the Annual General Meeting and to oversee voting process.

17. The cut-off date for the purpose of remote e-voting and voting at the AGM shall be Saturday, September 23, 2023. The voting right of members shall be in proportion to their shares in the paid up equity share capital of the Company as on Cut-off date.

18. The remote e-voting period begins on Wednesday, September, 27, 2023 at 09:00 a.m. and ends on Friday, September 29, 2023 at 5.00 p.m. During this period shareholders' of the Company, holding shares either in physical form or in dematerialized form, as on the cut-off date i.e., Saturday, September 23, 2023 may cast their vote electronically. The e-voting module shall be disabled by NSDL for voting thereafter. Once the vote on a resolution is cast by the member, the member shall not be allowed to change it subsequently.

19. The Members who have casted their vote by remote e-voting prior to the AGM may also attend the AGM but shall not be entitled to cast their vote again.

## 20. THE INSTRUCTIONS FOR MEMBERS FOR REMOTE E-VOTING ARE AS UNDER:-

**The remote e-voting period begins on Wednesday, September, 27, 2023 at 09:00 A.M. and ends on Friday, September 29, 2023 at 5.00 P.M. The remote e-voting module shall be disabled by NSDL for voting thereafter. The Members, whose names appear in the Register of Members / Beneficial Owners as on the record date (cut-off date) i.e. Saturday, September 23, 2023 may cast their vote electronically. The voting right of shareholders shall be in proportion to their share in the paid-up equity share capital of the Company as on the cut-off date, being Saturday, September 23, 2023.**

### **How do I vote electronically using NSDL e-Voting system?**

*The way to vote electronically on NSDL e-Voting system consists of "Two Steps" which are mentioned below:*

#### **Step 1: Access to NSDL e-Voting system**

##### **A) Login method for e-Voting for Individual shareholders holding securities in demat mode**

In terms of SEBI circular dated December 9, 2020 on e-Voting facility provided by Listed Companies, Individual shareholders holding securities in demat mode are allowed to vote through their demat account maintained with Depositories and Depository Participants. Shareholders are advised to update their mobile number and email Id in their demat accounts in order to access e-Voting facility. Login method for Individual shareholders holding securities in demat mode is given below:

Type of shareholders	Login Method
Individual Shareholders holding securities in demat mode with NSDL.	1. Existing <b>IDeAS</b> user can visit the e-Services website of NSDL Viz. <a href="https://eservices.nsd.com">https://eservices.nsd.com</a> either on a Personal Computer or on a mobile. On the e-Services home page click on the " <b>Beneficial Owner</b> " icon under " <b>Login</b> " which is available under ' <b>IDeAS</b> ' section, this will prompt you to enter your existing User ID and Password. After successful authentication, you will be able to see e-Voting services under Value added services. Click on " <b>Access to e-Voting</b> " under e-Voting services and you will be able to see e-Voting page. Click on company name or e-





**Voting service provider i.e. NSDL** and you will be re-directed to e-Voting website of NSDL for casting your vote during the remote e-Voting period. If you are not registered for IDEAS e-Services, option to register is available at <https://eservices.nsdl.com>. Select “**Register Online for IDEAS Portal**” or click at <https://eservices.nsdl.com/SecureWeb/IdeasDirectReg.jsp>

2. Visit the e-Voting website of NSDL. Open web browser by typing the following URL: <https://www.evoting.nsdl.com/> either on a Personal Computer or on a mobile. Once the home page of e-Voting system is launched, click on the icon “Login” which is available under ‘Shareholder/Member’ section. A new screen will open. You will have to enter your User ID (i.e. your sixteen digit demat account number hold with NSDL), Password/OTP and a Verification Code as shown on the screen. After successful authentication, you will be redirected to NSDL Depository site wherein you can see e-Voting page. Click on company name or **e-Voting service provider i.e. NSDL** and you will be redirected to e-Voting website of NSDL for casting your vote during the remote e-Voting period.
3. Shareholders/Members can also download NSDL Mobile App “**NSDL Speede**” facility by scanning the QR code mentioned below for seamless voting experience.

**NSDL Mobile App is available on**



Individual Shareholders holding securities in demat mode with CDSL

1. Users who have opted for CDSL Easi / Easiest facility, can login through their existing user id and password. Option will be made available to reach e-Voting page without any further authentication. The users to login Easi /Easiest are requested to visit CDSL website [www.cdslindia.com](http://www.cdslindia.com) and click on login icon & New System Myeasi Tab and then use your existing my easi username & password.
2. After successful login the Easi / Easiest user will be able to see the e-Voting option for eligible companies where the evoting is in progress as per the information provided by company. On clicking the evoting option, the user will be able to see e-Voting page of the e-Voting service provider for casting your vote during the remote e-Voting period. Additionally, there are also links provided to access the system of all e-Voting Service Providers, so that the user can visit the e-Voting service providers’ website directly.
3. If the user is not registered for Easi/Easiest, option to register is available at CDSL website [www.cdslindia.com](http://www.cdslindia.com) and click on login & New System Myeasi Tab and then click on registration option.

**ULTRA**

	4. Alternatively, the user can directly access e-Voting page by providing Demat Account Number and PAN No. from a e-Voting link available on <a href="http://www.cdslindia.com">www.cdslindia.com</a> home page. The system will authenticate the user by sending OTP on registered Mobile & Email as recorded in the Demat Account. After successful authentication, user will be able to see the e-Voting option where the evoting is in progress and also able to directly access the system of all e-Voting Service Providers.
Individual Shareholders (holding securities in demat mode) login through their depository participants	You can also login using the login credentials of your demat account through your Depository Participant registered with NSDL/CDSL for e-Voting facility. upon logging in, you will be able to see e-Voting option. Click on e-Voting option, you will be redirected to NSDL/CDSL Depository site after successful authentication, wherein you can see e-Voting feature. Click on company name or e-Voting service provider i.e. NSDL and you will be redirected to e-Voting website of NSDL for casting your vote during the remote e-Voting period.

**Important note:** Members who are unable to retrieve User ID/ Password are advised to use Forget User ID and Forget Password option available at [abovementioned website](#).

**Helpdesk for Individual Shareholders holding securities in demat mode for any technical issues related to login through Depository i.e. NSDL and CDSL.**

Login type	Helpdesk details
Individual Shareholders holding securities in demat mode with NSDL	Members facing any technical issue in login can contact NSDL helpdesk by sending a request at <a href="mailto:evoting@nsdl.co.in">evoting@nsdl.co.in</a> or call at 022 - 4886 7000 and 022 - 2499 7000
Individual Shareholders holding securities in demat mode with CDSL	Members facing any technical issue in login can contact CDSL helpdesk by sending a request at <a href="mailto:helpdesk.evoting@cdslindia.com">helpdesk.evoting@cdslindia.com</a> or contact at toll free no. 1800 22 55 33

**B) Login Method for e-Voting for shareholders other than Individual shareholders holding securities in demat mode and shareholders holding securities in physical mode.**

**How to Log-in to NSDL e-Voting website?**

1. Visit the e-Voting website of NSDL. Open web browser by typing the following URL: <https://www.evoting.nsdl.com/> either on a Personal Computer or on a mobile.
2. Once the home page of e-Voting system is launched, click on the icon "Login" which is available under 'Shareholder/Member' section.
3. A new screen will open. You will have to enter your User ID, your Password/OTP and a Verification Code as shown on the screen.

*Alternatively, if you are registered for NSDL eservices i.e. IDEAS, you can log-in at <https://eservices.nsdl.com/> with your existing IDEAS login. Once you log-in to NSDL eservices after using your log-in credentials, click on e-Voting and you can proceed to Step 2 i.e. Cast your vote electronically.*

4. Your User ID details are given below :

Manner of holding shares i.e. Demat (NSDL or CDSL) or Physical	Your User ID is:
a) For Members who hold shares in demat account with NSDL.	8 Character DP ID followed by 8 Digit Client ID For example if your DP ID is IN300*** and Client ID is 12***** then your user ID is





	IN300***12*****.
b) For Members who hold shares in demat account with CDSL.	16 Digit Beneficiary ID For example if your Beneficiary ID is 12***** then your user ID is 12*****
c) For Members holding shares in Physical Form.	EVEN Number followed by Folio Number registered with the company For example if folio number is 001*** and EVEN is 101456 then user ID is 101456001***

5. Password details for shareholders other than Individual shareholders are given below:
- If you are already registered for e-Voting, then you can use your existing password to login and cast your vote.
  - If you are using NSDL e-Voting system for the first time, you will need to retrieve the 'initial password' which was communicated to you. Once you retrieve your 'initial password', you need to enter the 'initial password' and the system will force you to change your password.
  - How to retrieve your 'initial password'?
    - If your email ID is registered in your demat account or with the company, your 'initial password' is communicated to you on your email ID. Trace the email sent to you from NSDL from your mailbox. Open the email and open the attachment i.e. a .pdf file. Open the .pdf file. The password to open the .pdf file is your 8 digit client ID for NSDL account, last 8 digits of client ID for CDSL account or folio number for shares held in physical form. The .pdf file contains your 'User ID' and your 'initial password'.
    - If your email ID is not registered, please follow steps mentioned below in **process for those shareholders whose email ids are not registered.**
6. If you are unable to retrieve or have not received the "Initial password" or have forgotten your password:
- Click on "**Forgot User Details/Password?**"(If you are holding shares in your demat account with NSDL or CDSL) option available on [www.evoting.nsdl.com](http://www.evoting.nsdl.com).
  - Physical User Reset Password?** (If you are holding shares in physical mode) option available on [www.evoting.nsdl.com](http://www.evoting.nsdl.com).
  - If you are still unable to get the password by aforesaid two options, you can send a request at [evoting@nsdl.co.in](mailto:evoting@nsdl.co.in) mentioning your demat account number/folio number, your PAN, your name and your registered address etc.
  - Members can also use the OTP (One Time Password) based login for casting the votes on the e-Voting system of NSDL.

- After entering your password, tick on Agree to "Terms and Conditions" by selecting on the check box.
- Now, you will have to click on "Login" button.
- After you click on the "Login" button, Home page of e-Voting will open.

## **Step 2: Cast your vote electronically on NSDL e-Voting system.**

### **How to cast your vote electronically on NSDL e-Voting system?**

- After successful login at Step 1, you will be able to see all the companies "EVEN" in which you are holding shares and whose voting cycle is in active status.
- Select "EVEN" of company for which you wish to cast your vote during the remote e-Voting period.
- Now you are ready for e-Voting as the Voting page opens.



4. Cast your vote by selecting appropriate options i.e. assent or dissent, verify/modify the number of shares for which you wish to cast your vote and click on "Submit" and also "Confirm" when prompted.
5. Upon confirmation, the message "Vote cast successfully" will be displayed.
6. You can also take the printout of the votes cast by you by clicking on the print option on the confirmation page.
7. Once you confirm your vote on the resolution, you will not be allowed to modify your vote.

#### **General Guidelines for shareholders**

1. Institutional shareholders (i.e. other than individuals, HUF, NRI etc.) are required to send scanned copy (PDF/JPG Format) of the relevant Board Resolution/ Authority letter etc. with attested specimen signature of the duly authorized signatory(ies) who are authorized to vote, to the Scrutinizer by e-mail to [csabhishek2@gmail.com](mailto:csabhishek2@gmail.com) with a copy marked to [evoting@nsdl.co.in](mailto:evoting@nsdl.co.in). Institutional shareholders (i.e. other than individuals, HUF, NRI etc.) can also upload their Board Resolution / Power of Attorney / Authority Letter etc. by clicking on "Upload Board Resolution / Authority Letter" displayed under "e-Voting" tab in their login.
2. It is strongly recommended not to share your password with any other person and take utmost care to keep your password confidential. Login to the e-voting website will be disabled upon five unsuccessful attempts to key in the correct password. In such an event, you will need to go through the "[Forgot User Details/Password?](#)" or "[Physical User Reset Password?](#)" option available on [www.evoting.nsdl.com](http://www.evoting.nsdl.com) to reset the password.
3. In case of any queries, you may refer the Frequently Asked Questions (FAQs) for Shareholders and e-voting user manual for Shareholders available at the download section of [www.evoting.nsdl.com](http://www.evoting.nsdl.com) or call on : 022 - 4886 7000 and 022 - 2499 7000 or send a request to Ms. Snehal Bhambe, Assistant Manager at [evoting@nsdl.co.in](mailto:evoting@nsdl.co.in)

#### **Process for those shareholders whose email ids are not registered with the depositories for procuring user id and password and registration of e mail ids for e-voting for the resolutions set out in this notice:**

1. In case shares are held in physical mode please provide Folio No., Name of shareholder, scanned copy of the share certificate (front and back), PAN (self attested scanned copy of PAN card), AADHAR (self attested scanned copy of Aadhar Card) by email to [cs@ultrawiring.com](mailto:cs@ultrawiring.com).
2. In case shares are held in demat mode, please provide DPID-CLID (16 digit DPID + CLID or 16 digit beneficiary ID), Name, client master or copy of Consolidated Account statement, PAN (self attested scanned copy of PAN card), AADHAR (self attested scanned copy of Aadhar Card) to [cs@ultrawiring.com](mailto:cs@ultrawiring.com). If you are an Individual shareholders holding securities in demat mode, you are requested to refer to the login method explained at **step 1 (A)** i.e. **Login method for e-Voting for Individual shareholders holding securities in demat mode.**
3. Alternatively shareholder/members may send a request to [evoting@nsdl.co.in](mailto:evoting@nsdl.co.in) for procuring user id and password for e-voting by providing above mentioned documents.
4. In terms of SEBI circular dated December 9, 2020 on e-Voting facility provided by Listed Companies, Individual shareholders holding securities in demat mode are allowed to vote through their demat account maintained with Depositories and Depository Participants. Shareholders are required to update their mobile number and email ID correctly in their demat account in order to access e-Voting facility.



## ANNEXURE TO NOTICE

Statement pursuant to Section 102 of the Companies Act, 2013 ("Act")

### General information as per Secretarial Standards 2 and Regulation 36 of SEBI(LODR) 2015 regarding Mr. Sanjay Mathur (Item No. 02)

Name of Director	Mr. Sanjay Mathur
Director Identification Number (DIN)	00285032
Date of birth	29 <sup>th</sup> August, 1964
Nationality	Indian
Date of Appointment on Board	1 <sup>st</sup> June, 2005
Relationships between Directors Inter-se	Mrs. Archana Mathur-Spouse
Area of Experience	Professional experience in engineering as well as administration
Shareholding in Ultra Wiring Connectivity System Limited	13,04,600 Equity Shares
List of Directorships held in other Companies (excluding foreign, private and Section 8 Companies)	NIL
Memberships / Chairmanships of Audit and Stakeholders' Relationship Committees across Public Companies	2

### Item No. 3 To increase the remuneration of Mr. Sanjay Mathur (DIN00285032), Managing Director of the Company

Mr. Sanjay Mathur, aged 59 years is a Managing Director of the Company having over 36 years of industry experience in engineering as well as administration. He has done his graduation in mechanical engineering.

The Board of Directors is of the opinion that considering his expertise and efforts for the company, his terms of remuneration needs to be revised. In terms of the provisions of the Act and the Articles of Association of the Company, the Nomination and Remuneration Committee and the Board of Directors have at their meetings held on May 27, 2023 has decided to increase his remuneration

The abstract of terms and conditions of revised remuneration are as follows:

- A. He will be designated as **Managing Director**.
- B. Remuneration
- a). **Salary:** Current Salary of Rs.4,00,000 per month; The annual increments which will be effective 1st April each year, will be decided by the Board based on the recommendation of the Nomination and Remuneration Committee (hereinafter called the "NRC") and will be performance-based and take into account the Company's performance as well, within the said maximum amount.
- b). **Perquisites:** The Managing Director shall be entitled to the following perquisites classified into Categories 'A' & 'B':

#### Category - A:

- House Rent Allowance;
- House Maintenance;





- Station Allowance;
- Medical Reimbursement;
- Soft Furnishing;
- Provision for use of Company's car and fuel and other facilities/ reimbursements for official purpose which will not be considered as perquisites.

**Category - B:**

- Company's contribution to Provident Fund and Superannuation Fund or Annuity Fund shall not be included in the computation of the ceiling on perquisites to the extent these either singly or put together are not taxable under the provisions of the Income Tax Act;
  - Gratuity as per Rules of the Company;
  - Encashment of Leave, as per Rules of the Company.
- C. **Functions**-He shall exercise duties and functions as may be delegated/ assigned to him by the Board of Directors/Committee of Directors from time to time.
- D. **Sitting Fee**-He shall not be paid any sitting fee for attending the Meeting of Board or Committee thereof.

**Item No. 4 Revision in the terms and conditions of remuneration of Mrs. Archana Mathur (DIN 00285041), Director of the Company**

Mrs. Archana Mathur, aged 54 years is a Director of the Company having industry experience in Business management as well as administration.

In terms of the provisions of the Act and the Articles of Association of the Company, the Nomination and Remuneration Committee and the Board of Directors have at their meetings held on May 27, 2023 has decided to revise her terms of remuneration.

The abstract of revised terms and conditions of remuneration are as follows:

- A. She will be designated as **Director**.
- B. Remuneration
- a) **Salary:** Current Salary of Rs. 4,00,000 per month; The annual increments which will be effective 1st April each year, will be decided by the Board based on the recommendation of the Nomination and Remuneration Committee (hereinafter called the "NRC") and will be performance-based and take into account the Company's performance as well, within the said maximum amount.
- b) **Perquisites:** She will be entitled to the following perquisites classified into Categories 'A' & 'B':

**Category - A:**

- House Rent Allowance;
- House Maintenance;
- Station Allowance;
- Medical Reimbursement;
- Soft Furnishing;
- Provision for use of Company's car and fuel and other facilities/ reimbursements for official purpose which will not be considered as perquisites.

**Category - B:**

- Company's contribution to Provident Fund and Superannuation Fund or Annuity Fund shall not be included in the computation of the ceiling on perquisites to the extent these either singly or put together are not taxable under the provisions of the Income Tax Act;
  - Gratuity as per Rules of the Company;
  - Encashment of Leave, as per Rules of the Company.
- C. **Functions**-She shall exercise duties and functions as may be delegated/ assigned to her by the Board of Directors/Committee of Directors from time to time.



- D. **Sitting Fee**-She shall not be paid any sitting fee for attending the Meeting of Board or Committee thereof.

**Item No. 5 Approval for Related Party Transaction**

For the purpose of ease of business and in compliance of Section 188 of the Act and pursuance to the authorization given by Board to the Audit Committee members, it is hereby proposed to give omnibus approval to certain regular business transactions with the related parties as it deemed fit to the audit committee, subject to approval by shareholders in the ensuing 18<sup>th</sup> AGM of the Company.

Section 188 of the Act and the applicable Rules framed there under provide that any Related Party Transaction will require prior approval of shareholders through ordinary resolution, if the aggregate value of transaction(s) amounts to 10% or more of the annual turnover of the Company as per last audited financial statements of the Company. However the above said transaction will be carried on arm's length basis and it will not hit the above said threshold since the value of proposed aggregate transactions will not exceed Rs. 50 Lacs during the financial year, but the proposed transactions will be done with the persons come under the definition of related parties as per the Act.

Accordingly, the proposed transaction(s) will come within the meaning of Related Party transaction(s) in terms of provisions of the Act, applicable rules framed there under read with the Listing Regulations. Hence, approval of the shareholders is being sought for the said Related Party Transaction(s) proposed to be entered into by your Company the financial year 2023-24.

The members may consider the matter and pass the recommended resolution.



# ROUTE MAP TO THE VENUE OF 18<sup>th</sup> ANNUAL GENERAL MEETING OF ULTRA WIRING CONNECTIVITY SYSTEM LIMITED

(Formerly known as Ultra Wiring Connectivity System Private Limited)

## VENUE

PLOT NO.287, 287 A, 287B, SECTOR-59 HSIIDC INDL. ESTATE, BALLABGARH FARIDABAD 121004

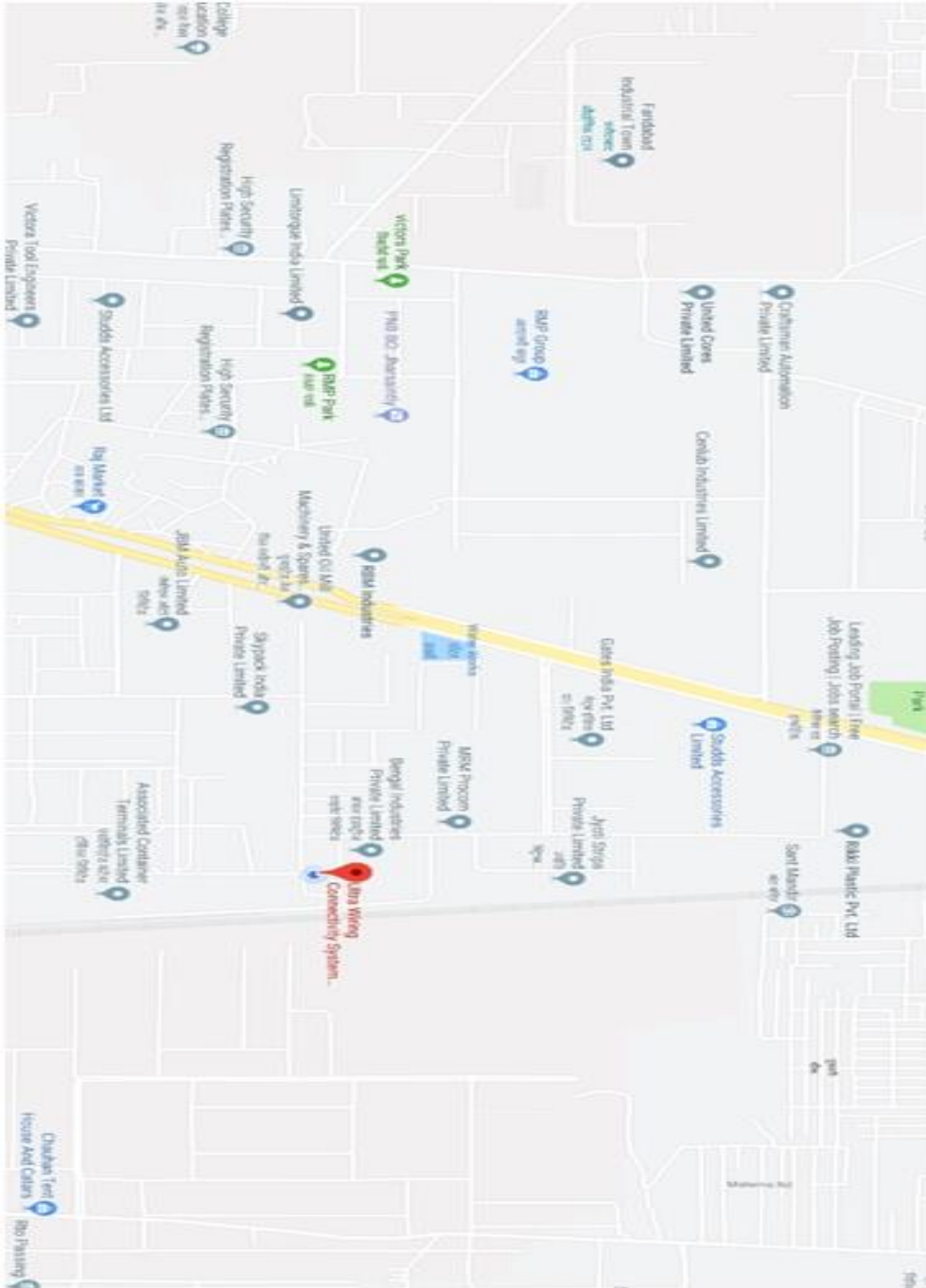



## DIRECTOR'S REPORT

To,

**The Members,**

Ultra Wiring Connectivity System Limited

(Formerly known as Ultra Wiring Connectivity System Private Limited)

Your directors take pleasure in presenting the 18<sup>th</sup> Annual Report together with the Audited Accounts for the financial year ended March 31, March 2023.

### 1. **FINANCIAL RESULTS:**

The Financial Statements for the Financial Year ended on March 31, 2023, forming part of the Director's Report, has been prepared in accordance with the Companies Act, 2013 and the rules made thereunder.

The financial performance of the Company for the Financial Year ended on March 31, 2023 is summarised as below:

(Figures in Lacs)

Particulars	2022-23	2021-22
<b>Revenue from Operations</b>	4,433.45	2,945.87
Other Income	10.44	20.44
<b>Total Income</b>	4,443.89	<b>2,966.31</b>
<b>Expenses</b>		
Production Cost	2,849.47	1913.46
Changes in inventories of Finished goods, work-in-progress, Stock in Trade	14.26	(29.02)
Employee Benefit Expenses	463.13	326.10
Finance Cost	48.50	28.99
Depreciation and Amortization expenses	92.16	65.78
Other Expenses	674.16	464.54
<b>Total Expenses</b>	4,141.68	<b>2769.85</b>
<b>Net Profit Before Exceptional Items and Tax</b>	302.21	196.46
Exceptional items	-	-
<b>Net Profit Before Tax</b>	302.21	<b>196.46</b>
Tax Expenses	79.69	46.15
<b>Profit for the Year</b>	222.52	<b>150.31</b>

### 2. **COMPANY'S PERFORMANCE REVIEW:**

The Company operates in the auto components industry and is engaged in production and manufacturing of Couplers, Connectors and allied products Blade Fuse and Wiper-Blades for OEMs and Tier 1 manufacturers. The total revenue from operations for the FY 2022-23 is Rs. 4,433.45 Lacs as against 2,945.87 Lacs in the previous year, which shows the considerable increased of 50.49%. Profit before tax of the Company has also grown by 53.82% to Rs. 302.21 Lacs as against 196.46 Lacs in the previous



year.

The prospective vision of the Company with the evaluation of the business and operations of the Company are provided in the Report on Management Discussion and Analysis forming part of the Annual Report.

**3. DIVIDEND:**

Considering the funds requirement for future expansion and to face the existing market challenges, no dividend is proposed to the members for Financial Year 2022-23, as per the Companies (Declaration and Payment of Dividend) Rules, 2014.

**4. LISTING:**

The Company's shares are listed on the National Stock Exchange Ltd. (NSE) - Emerge and are actively traded. The listing fee for the year 2023-24 has already been paid.

**5. HOLDING, SUBSIDIARIES AND ASSOCIATES:**

The Company does not have any holding, subsidiary and associate Company.

**6. TRANSFER TO RESERVES:**

During the year under review, the Company has transferred Rs. 22252150 to General Reserve for future expansion and to face the existing market challenges.

**7. PARTICULARS OF LOANS, GUARANTEE OR INVESTMENT UNDER SECTION 186 OF THE COMPANIES ACT, 2013**

Details of loans, guarantees and investments covered under the provisions of Section 186 of the Companies Act, 2013, wherever applicable, are given in the notes to financial statements.

**SHARE CAPITAL:**

There is no change in the Authorized and paid up Share Capital of the Company during the period under review.

The Authorized Share Capital of the Company is Rs. 5,50,00,000.00 divided into 55,00,000 Equity Shares of Rs. 10/- each.

The paid up Equity Share Capital of the Company is Rs. 5,20,35,710.00 divided into 52,03,571 Equity Shares of Rs. 10/- each.

• **Issue of Equity Shares with Differential Rights:-**

During the period under review, the Company has not issued any Equity Shares with Differential Rights.

• **Issue of Employee Stock Options:-**

During the period under review, the Company has not issued any Employee Stock Options as stated in Rule 12(9) of Companies (Share Capital and Debenture Rules, 2014).



- **Issue of Sweat Equity Shares-:**

During the period under review, the Company has not issued any sweat equity shares as specified in Rule 8(13) of Companies (Share Capital and Debenture Rules, 2014).

**During the year under review-:**

(a) Issue of equity Shares with differential rights	: Nil
(b) Issue of sweat equity shares	: Nil
(c) Issue of employee stock options	: Nil
(d) Provision of money by company for purchase of its own shares by employees or by trustees for the benefit of employees	: Nil
(e) Debentures	: Nil

**8. OTHER DISCLOSURES UNDER THE COMPANIES ACT, 2013:**

**i. EXTRACT OF THE ANNUAL RETURN:**

In accordance with the Companies Act, 2013, Annual Return in the prescribed format is available at Company's website at <https://www.ultrawiring.com>.

**ii. NUMBER OF BOARD MEETINGS CONDUCTED DURING THE YEAR:**

The Directors of the Company met at regular intervals at least once in a quarter with the gap between two meetings not exceeding 120 days to take a view of the Company's policies and strategies apart from the Board Matters.

The Board met Six (6) times during the financial year 2022-23 i.e May 06, 2022, May 28, 2022, August 29, 2022, November 14, 2022, January 28, 2023 and February 20, 2023. The maximum interval between any two meetings did not exceed 120 days.

**iii. GENERAL MEETINGS:**

During the year under review Extra Ordinary General Meeting (EGM) was held on March 25, 2023 to approve the reappointment of Independent Directors.

**iv. COMMITTEES OF THE BOARD:**

The Board had constituted various committees which are as follows:

**a. Audit Committee:**

The Company has constituted an Audit Committee, as per the provisions of Section 177 of the Companies Act, 2013 The Committee presently comprises of following three (3) Directors:

Name of the Directors	Status	Nature of Directorship
Mr. Aditya Mathur	Chairman	Non-Executive and Independent Director





Mr. Rajindarr Ahuja	Member	Non-Executive and Independent Director
Mr. Sanjay Mathur	Member	Managing Director

The Role and powers of the committee are as under:

- 1) Overseeing the Company's financial reporting process and the disclosure of its financial information to ensure that the financial statements are correct, sufficient and credible.
- 2) Recommending to the Board, the appointment, re-appointment and, if required, the replacement or removal of the statutory auditor
- 3) and the fixation of audit fees.
- 4) Approval of payment to statutory auditors for any other services rendered by the statutory auditors.
- 5) Reviewing, the annual financial statements before submission to the board for approval, with particular reference to:
  - a. Matters required to be included in the Directors Responsibility Statement in the Board's report in terms of clause (c) of sub-section 3 of Section 134 of the Companies Act, 2013.
  - b. Changes, if any, in accounting policies and practices and reasons for the same.
  - b. Major accounting entries involving estimates based on the exercise of judgment by management.
  - c. Significant adjustments made in the financial statements arising out of audit findings.
  - d. Compliance with listing and other legal requirements relating to financial statements.
  - e. Disclosure of any related party transactions.
  - f. Modified opinion(s) in the draft audit report.
- 6) Reviewing, with the management, the half yearly and annual financial statements before submission to the board for approval.
- 7) Reviewing, with the management, the statement of uses / application of funds raised through an issue (public issue, rights issue, preferential issue, etc.), the statement of funds utilized for purposes other than those stated in the offer document/prospectus/notice and the report submitted by the monitoring agency monitoring the utilization of proceeds of a public or rights issue, and making appropriate recommendations to the Board to take up steps in this matter.
- 8) Reviewing and monitoring the auditor's independence and performance and effectiveness of audit process.
- 9) Approval of any transactions of the Company with Related Parties, including any subsequent modification thereof.
- 10) Scrutiny of inter-corporate loans and investments.
- 11) Valuation of undertakings or assets of the Company, wherever it is necessary.
- 12) Evaluation of internal financial controls and risk management systems.
- 13) Reviewing, with the management, performance of statutory and internal auditors, and adequacy of the internal control systems.
- 14) Reviewing the adequacy of internal audit function, if any, including the structure of the internal audit department, staffing and seniority of the official heading the department, reporting structure coverage and frequency of internal audit.
- 15) Discussion with internal auditors on any significant findings and follow up there on.
- 16) Reviewing the findings of any internal investigations by the internal auditors into matters where there is suspected fraud or irregularity or a failure of internal control systems of a material nature and reporting the matter to the board.



- 17) Discussion with statutory auditors before the audit commences, about the nature and scope of audit as well as post-audit discussion to ascertain any area of concern.
- 18) To look into the reasons for substantial defaults in the payment to the depositors, debenture holders, shareholders (in case of non-payment of declared dividends) and creditors.
- 19) To review the functioning of the Whistle Blower mechanism, in case the same exists.
- 20) Approval of appointment of CFO or any other person heading the finance function or discharging that function after assessing the qualifications, experience & background, etc. of the candidate.
- 21) To overview the Vigil Mechanism of the Company and take appropriate actions in case of repeated frivolous complaints against any Director or Employee.
- 22) To implement Ind AS (Indian Accounting Standards), whenever required.
- 23) Monitoring the end use of funds raised through public offers and related matters. The Audit Committee shall mandatorily review the following information:
  1. Management Discussion and Analysis of financial condition and results of operations.
  2. Statement of significant related party transactions (as defined by the Audit Committee), submitted by management.
  3. Management letters / letters of internal control weaknesses issued by the statutory auditors.
  4. Internal audit reports relating to internal control weaknesses.
  5. The appointment, removal and terms of remuneration of the chief internal auditor shall be subject to review by the audit committee.

**24) Statement of deviations:**

- a) Half yearly statement of deviation(s) including report of monitoring agency, if applicable, submitted to stock exchange(s) in terms of Regulation 32(1).
- b) Annual statement of funds utilized for purposes other than those stated in the offer document/prospectus/notice in terms of Regulation 32(7).

**POWERS OF THE AUDIT COMMITTEE:**

- Investigating any activity within its terms of reference;
- Seeking information from any employee;
- Obtaining outside legal or other professional advice; and
- Securing attendance of outsiders with relevant expertise, if it considers necessary.

**b. Stakeholder Relationship Committee:**

The Company has constituted a Stakeholders Relationship Committee as per the provisions of Section 178(5) of the Companies Act, 2013. The Committee presently comprises of following three (3) Directors:

Name of the Directors	Status	Nature of Directorship
Mr. Aditya Mathur	Chairman	Non-Executive and Independent Director
Mr. Rajindarr Ahuja	Member	Non-Executive and Independent Director
Mr. Sanjay Mathur	Member	Managing Director

The Stakeholder Relationships Committee shall oversee all matters pertaining to investors of our Company. The terms of reference of the Investor Grievance Committee include the following:

1. Redressal of shareholders'/investors' complaints;
2. Reviewing on a periodic basis the Approval of transfer or transmission of shares, debentures



or any other securities made by the Registrar and Share Transfer Agent;

3. Issue of duplicate certificates and new certificates on split/consolidation/renewal;
4. Non-receipt of declared dividends, balance sheets of the Company; and
5. Carrying out any other function as prescribed under the SEBI (Listing Obligation and Disclosure Requirements) Regulations, 2015.

c. **Nomination and Remuneration Committee:**

The Company has constituted a Nomination and Remuneration Committee as per the provisions of Section 178 of the Companies Act, 2013. The Committee presently comprises of following three (3) Directors:

<b>Name of the Directors</b>	<b>Status</b>	<b>Nature of Directorship</b>
Mr. Aditya Mathur	Chairman	Non-Executive and Independent Director
Mr. Rajindarr Ahuja	Member	Non-Executive and Independent Director
Mr. Sanjay Mathur	Member	Managing Director

**ROLE OF THE COMMITTEE:**

Role of Nomination and Remuneration Committee are as under:

- a) Formulation of the criteria for determining qualifications, positive attributes and independence of a director and recommend to the Board of Directors a policy relating to, the remuneration of the directors, Key Managerial Personnel and other associates.
- b) Formulation of criteria for evaluation of performance of Independent Directors and the Board of Directors.
- c) Devising a policy on diversity of Board of Directors.
- d) Identifying persons who are qualified to become directors and who may be appointed in senior management in accordance with the criteria laid down, and recommend to the Board of Directors their appointment and removal.
- e) Whether to extend or continue the term of appointment of the Independent Director, on the basis of the report of performance evaluation of Independent Directors.
- f) Such other matters as may from time to time be required by any statutory, contractual or other regulatory requirements to be attended to by such committee.

vi. **CHANGES IN NATURE OF BUSINESS:**

There has been no change in the nature of business of the Company during the financial year ended March 31, 2023.

vii. **RELATED PARTY TRANSACTIONS:**

All related party transactions are presented to the Audit Committee and the Board. Advanced approval is obtained for the transactions which are foreseen and repetitive in nature. A statement of all related party transactions is presented before the Audit Committee periodically, specifying the nature, value and terms and conditions of the transactions.





During the year, the Company has not entered into any arrangement/transaction with related parties which could be considered material in accordance with the Company's Policy on Related Party Transactions.

Further all the necessary details of transaction entered with the related parties are attached herewith in Form No. AOC-2 for your kind perusal and information.(Annexure A).

**9. SHIFTING OF REGISTERED OFFICE OF THE COMPANY**

The Company has made an application to the Hon'ble Regional Director Delhi (North Region) for shifting of its registered office from B-78, Nirman Vihar, New Delhi- 110092 to Plot No 287, 287 A & B, Sector 59, HSIIDC Industrial estate, Ballabgarh, Faridabad- 121004. The Hon'ble Regional Director, has passed order dated July 26, 2019 for the confirmation of shifting of registered office from National Capital Territory of Delhi to Haryana. Further the Company has shifted its registered office to the above said place with effect from 26<sup>th</sup> August 2019. In this regard the Company has also received the certificate from the Registrar of Companies, NCT of Delhi & Haryana dated 26th July 2019.

**10. WHISTLE BLOWER POLICY/VIGIL MECHANISM/ RISK MANAGEMENT:**

In order to ensure that the activities of the Company and its employees are conducted in a fair and transparent manner by adoption of highest standards of professionalism, honesty, integrity and ethical behaviour, the Company has adopted a Vigil Mechanism Policy/ Whistle Blower policy.

In today's challenging and competitive environment, strategies for mitigating inherent risks in accomplishing the growth plans of the Company are imperative. The common risks inter alia are: regulations, competition, business risk, investments, retention of talent and expansion of facilities. Business risk, inter-alia, further includes financial risk, political risk, fidelity risk, legal risk. These risks are assessed and steps as appropriate are taken to mitigate the same. The management has taken all necessary steps to identify the elements of risks, if any. The management has implemented an effective and meaningful system to safeguard the assets of the company. The Board has to review the business plan at regular intervals and develop the Risk Management Strategy which shall encompass laying down guiding principles on proactive planning for identifying, analyzing and mitigating all the material risks, both external and internal viz. environmental, business, operational, financial and others. Communication of Risk Management Strategy to various levels of management for effective implementation is essential for achieving the goals of the organisation.

In compliance with the requirement of the Companies Act, 2013 and SEBI Listing Regulations, the Company has established a Whistle Blower Policy / Vigil Mechanism Policy and the same is placed on the web site of the Company viz. [www.ultrawiring.com](http://www.ultrawiring.com)

**11. STATUTORY AUDITORS. THEIR REPORT AND NOTES TO FINANCIAL STATEMENTS AND FRAUD. IF ANY:**

As per the requirements of the Companies Act, 2013 the Audit Committee and the Board of Directors at their meeting held on August 23, 2019 has re-appointed M/S. Sanmarks & Associates, Chartered



Accountants (Firm Registration No. 003343N) as Statutory Auditors of the Company till the conclusion of AGM to be held in 2024.

The Company has received a certificate from statutory auditors to the effect that their re-appointment is within the limits prescribed under Section 141(3)(g) of the Companies Act, 2013 and they are not disqualified to be re-appointed as Statutory Auditors.

Further, the report of the Statutory Auditors along with the notes is enclosed with the financial statements. The observations made in the Auditors' Report which contains unmodified opinion are self-explanatory and does not contain any qualification/modified opinion. Therefore, it does not call for any further comments. Also the Auditors of the Company have not reported any fraud as specified under Section 143(12) of the Companies Act, 2013.

Note: The provisions of ratification of appointment of auditors have been omitted.

## **12. SECRETARIAL AUDITOR:**

Pursuant to Section 204 of the Companies Act, 2013 the Board of Directors had appointed M/s Abhishek J & Co., Practicing Company Secretary to undertake the Secretarial Audit of the Company for the period 2022-23.

The Secretarial Audit Report for the FY 2022-23 is self-explanatory and does not call for any further comments. The Secretarial Audit Report for the FY 2022-23 is attached to this report as "**Annexure B**".

## **13. DISCLOSURE OF SECRETARIAL STANDARDS:**

During the Financial Year 2022-23, the Company has complied with the provisions of applicable Secretarial Standards issued by the Institute of Company Secretaries of India (ICSI).

## **14. UPDATES ON BOARD OF DIRECTORS/KEY MANAGERIAL PERSONNEL (KMP):**

### **a) PERFORMANCE EVALUATION:**

In compliance with the Companies Act, 2013, and SEBI (Listing Obligations and Disclosure Requirements) Regulations, 2015, the annual evaluation has been carried out by the Board of its own performance, of its committees and Directors by way of individual and collective feedback from Directors. The Directors expressed their satisfaction with the evaluation process.

### **b) DIRECTORS AND KEY MANAGERIAL PERSONNEL:**

The Composition of the Board of Directors and Key Managerial Personnel are as follow.

<b>Sr. No</b>	<b>Name of the Director and other KMP'S</b>	<b>Designation</b>
1	Mr. Sanjay Mathur	Managing Director
2	Mrs. Archana Mathur	Director
3	Mr. Aditya Mathur	Independent Director
4	Mr. Rajindarr Ahuja	Independent Director
5	Mr. Prabhat Bhatia	Chief Financial Officer
6	Mrs. Sarita Chaurasia	Company Secretary & Compliance Officer



## **DETAILS OF DIRECTORS AND KEY MANAGERIAL PERSONNEL**

### **APPOINTED/RESIGNED/RETIRED DURING THE YEAR-**

#### **Changes in Directors and Key Managerial Personnel**

In terms of provisions of section 149(10) of the Companies Act, 2013, an independent director shall hold office for a term up to five consecutive years on the Board of a Company, but shall be eligible for reappointment on passing of a special resolution by the Shareholders of the Company.

Keeping in view the recommendations of the Nomination & Remuneration Committee as per section 178 of the Companies Act, 2013, the Board of Directors of the Company, in its meeting held on January 28, 2023, has recommended the re-appointed of Mr. Rajinder Ahuja (DIN: 08069485) and Mr. Aditya Mathur (DIN: 02109156) effective from February 15, 2023 and March 01, 2023 respectively in the capacity of an Independent Directors of the Company, not liable to retire by rotation, subject to approval of shareholders of the company.

At the Extra-ordinary General Meeting (EGM) of the company held on March 25, 2023 the consent of the shareholders has also been obtained for the above said re-appointments.

#### **Retirement of director by rotation:**

Pursuant to the provisions of Section 152 of the Companies Act, 2013, Mr. Sanjay Mathur, (DIN: 00285032), Director is liable to retire by rotation at the ensuing Annual General Meeting and being eligible, He offered himself for re-appointment. Accordingly, the proposal for his re-appointment has been included in the Notice convening the Annual General Meeting of the Company.

Brief resume, nature of expertise, details of directorships held in other companies of the Directors proposed to be re-appointed, along with their shareholding in the Company, as stipulated under Secretarial Standard 2 and Regulation 36 of the Listing Regulations, is appended as an Annexure to the Notice of the ensuing Annual General Meeting.

#### **c) CODE OF CONDUCT:**

The Company has formulated a code of conduct for Board of Directors and Senior Managerial Personnel. The confirmation of compliance of the same is obtained from all concerned on an annual basis. All Board Members and Senior Managerial Personnel have given their confirmation of compliance for the year under review. The code of conduct for Directors and Senior Managerial Personnel is also placed on the website of the Company viz. [www.ultrawiring.com](http://www.ultrawiring.com).

#### **d) FAMILIARISATION PROGRAMME FOR INDEPENDENT DIRECTORS:**

The Company proactively keeps its Directors informed of the activities of the Company, its management, operations and provides an overall industry perspective as well as issues faced by the industry. The Policy on Familiarization Programme adopted by the Board of director and details of the same are available on the Company's website under the Investors Relations section of the website at [www.ultrawiring.com](http://www.ultrawiring.com).



**15. MANAGEMENT DISCUSSION AND ANALYSIS REPORT:**

As required by Regulation 34 (2) of the SEBI (Listing Obligations and Disclosure Requirements) Regulations, 2015 a detailed Management Discussion and Analysis Report is presented in a separate section forming part of the Annual Report marked as “**Annexure-C**”.

**16. MATERIAL CHANGES AND COMMITMENTS**

There have been no material changes and commitments, which affect the financial position of the company which have occurred between the end of the financial year to which the financial statements relate and the date of this Report.

**17. DEPOSITS:**

Your Company has not accepted deposits within the meaning of Section 73 and 76 of the Companies Act, 2013 and the Companies (Acceptance of Deposits) Rules, 2014. The question of non-compliance of the relevant provisions of the law relating to acceptance of deposit does not arise.

**18. CORPORATE SOCIAL RESPONSIBILITY:**

The provisions of Section 135 of the Companies Act, 2013 relating to Corporate Social Responsibility is not applicable to the Company as the Company does not fall under the prescribed criteria.

**19. CORPORATE GOVERNANCE:**

The provisions of the Corporate Governance regulations shall not be applicable to the Company, since according to the provisions of Regulation 15(2)(b) of Chapter IV of SEBI (Listing Obligations and Disclosure Requirements) Regulations, 2015 i.e. “**The listed entity which has listed its specified securities on the SME Exchange are not liable to file the Corporate Governance Report** under regulation 27(2) of SEBI (Listing Obligations and Disclosure Requirements) Regulations, 2015”.

**20. INTERNAL FINANCIAL CONTROL WITH REFERENCE TO FINANCIAL STATEMENTS:**

The Company has adequate internal financial control procedure commensurate with its size and nature of business. These controls include well defined policies, guidelines, standard operating procedure, authorization and approval procedures. The internal financial control of the company are adequate to ensure the accuracy and completeness of the accounting records, timely preparation of reliable financial information, prevention and detection of frauds and errors, safeguarding of the assets, and that the business is conducted in an orderly and efficient manner.

**21. SIGNIFICANT AND MATERIAL ORDERS PASSED BY THE REGULATORS OR COURTS OR TRIBUNALS IMPACTING THE GOING CONCERN STATUS AND COMPANY’S OPERATIONS IN FUTURE:**

During the year under review, there have been no such significant and material orders passed by the regulators or courts or tribunals impacting the going concern status and company’s operations in future.





**22. DISCLOSURE UNDER SEXUAL HARASSMENT OF WOMEN AT WORKPLACE (PREVENTION, PROHIBITION& REDRESSAL) ACT, 2013:**

The Company has in place a Prevention of Sexual Harassment Policy in line with the requirements of the Sexual Harassment of Women at the Workplace (Prevention, Prohibition and Redressal) Act, 2013. An Internal Complaints Committee has been duly constituted to redress complaints received regarding sexual harassment. All employees (permanent, contractual, temporary, trainees) are covered under this policy.

During the year 2022-23, no complaints were received by the Company related to sexual harassment.

**23. CODE OF CONDUCT FOR THE PREVENTION OF INSIDER TRADING**

The Company has adopted a code of conduct for prevention of insider trading with a view to regulate trading in securities by the Directors and designated employees of the Company. The code requires pre-clearance for dealing in the Company's shares and prohibits the purchase or sale of Company shares by the Directors and the designated employees while in possession of Un-Published Price Sensitive Information (UPPSI) in relation to the Company and during the period when the trading window is closed. The Board is responsible for implementation of the code.

The Code of fair disclosure of unpublished price sensitive information is available on the Company's website under the Investors Relations section at [www.ultrawiring.com](http://www.ultrawiring.com).

**24. PARTICULARS OF EMPLOYEE:**

The Company has no employee who is in receipt of remuneration of Rs.8,50,000/-per month or Rs.1,02,00,000/- per annum.

Information in accordance with the provisions of Section-134 (3) (q) and Section 197(12) of the Act read with Rule 5(1) & Rule 5(2) of the Companies (Appointment and Remuneration of Managerial Personnel) Rules, 2014 are appended as "Annexure D"

**25. CONSERVATION OF ENERGY, TECHNOLOGY ABSORPTION, FOREIGN EXCHANGE EARNINGS AND OUTGO:**

**A. CONSERVATION OF ENERGY AND TECHNOLOGY ABSORPTION:**

The Particulars required under the provisions of Section 134(3) (m) of the Companies Act, 2013 in respect of conservation of energy and technology absorption have not been furnished considering the nature of activities undertaken by the company during the year under review.

**B. FOREIGN EXCHANGE EARNINGS AND OUTGO:**

Details of Foreign exchange earnings and outgo are as follows (in Rs)

Particulars	2022-23
Foreign Exchange Earned	NIL
Foreign Exchange used for Import Purchase and Capital Goods	2,75,70,412.67



**26. DIRECTORS RESPONSIBILITY STATEMENT:**

Pursuant to the provisions of section 134(5) of the Companies Act, 2013, your Directors confirm:-

1. That in the preparation of Annual Accounts, the applicable accounting standards have been followed and there are no material departures;
2. That we have selected such accounting policies and applied them consistently and made judgments and estimates that are reasonable and prudent, so as to give a true and fair view of the state of affairs of the Company as at March 31, 2023 and of the losses of the Company for the period ended March 31, 2023;
3. That we have taken proper and sufficient care for the maintenance of adequate accounting records in accordance with the provisions of the Companies Act, 2013 for safeguarding the assets of the Company and for preventing and detecting frauds and other irregularities;
4. That we have prepared the Annual Accounts on a going concern basis;
5. That we have laid down internal financial controls to be followed by the Company and such internal financial controls are adequate and operating effectively;
6. That we have devised proper systems to ensure compliance with the provisions of all applicable laws and that such systems were adequate and operating effectively.

**27. ACKNOWLEDGEMENTS:**

Your Directors hereby express their appreciation for the cooperation and assistance received from stakeholders, banks, valued clients and business associates. Your Directors also wish to place on record their deep sense of appreciation for the diligent support and efforts of the employees at all levels towards the operations and growth of the Company.

**FOR ULTRA WIRING CONNECTIVITY SYSTEM LIMITED**

Sd/-

**Sanjay Mathur**  
**Chairman & Managing Director**  
**(DIN 00285032)**

Date: August 21, 2023

Place: Faridabad



**FORM NO. AOC-2**

(PURSUANT TO CLAUSE (h) OF SUB-SECTION (3) OF SECTION 134 OF THE ACT AND  
RULE 8 (2) OF THE COMPANIES (ACCOUNTS) RULES, 2014)

**DISCLOSURE OF PARTICULARS OF CONTRACTS/ARRANGEMENTS ENTERED INTO BY THE COMPANY WITH RELATED PARTIES REFERRED TO IN SUB-SECTION (1) OF SECTION 188 OF THE COMPANIES ACT, 2013 INCLUDING CERTAIN ARM'S LENGTH TRANSACTIONS UNDER THIRD PROVISIO THERETO.**

**1. DETAILS OF CONTRACTS OR ARRANGEMENTS OR TRANSACTIONS NOT AT ARM'S LENGTH BASIS**

There were no contracts or transactions entered into during the year ended March 31, 2023, which were not at arm's length basis.

**2. DETAILS OF MATERIAL CONTRACTS OR ARRANGEMENTS OR TRANSACTIONS AT ARM'S LENGTH BASIS.**

The details of material contracts, arrangements or transactions in the ordinary course of business and at arm's length basis for the year ended March 31, 2023 are as follows:

(In lakhs)

Name(s) of the Related Party	Nature of relationship	Nature of Transaction	Duration of Transaction	Salient Terms of Transaction including the value, if any	Date(s) of approval by the board	Amount paid as advances, if any
Ultra Auto Components	A firm controlled by director who hold more than 2 percent	-	April 01,2022 – March 31, 2023	Nil	Nil	Nil
Ultra Harness Industries	A firm controlled by director who hold more than 2 percent	Payment to Creditor	April 01,2022 – March 31, 2023	5.81	Nil	Nil

For and on behalf of the board  
**ULTRA WIRING CONNECTIVITY SYSTEM LIMITED**

Sd/-  
**Sanjay Mathur**  
Managing Director  
(DIN: 00285032)

Date: August 21, 2023  
Place: Faridabad



**SECRETARIAL AUDIT REPORT****FOR THE FINANCIAL YEAR ENDED 31<sup>st</sup> MARCH, 2023****{Pursuant to Section 204(1) of the Companies Act, 2013 and rule 9 of the Companies (Appointment and Remuneration of Managerial Personnel) Rules, 2014}**

To,  
The Members,  
**Ultra Wiring Connectivity System Limited**

I have conducted the Secretarial Audit of the Compliance of applicable statutory provisions and the adherence to good corporate practices by **Ultra Wiring Connectivity System Limited** (hereinafter called Ultra / the Company). Secretarial Audit was conducted in a manner that provided me a reasonable basis for evaluating the corporate conducts/statutory compliances and expressing my opinion thereon.

Based on my verification of the Company books, papers, minute books, forms and returns filed and other records maintained by the company and also the information provided by the Company, its officers, agents and authorized representatives during the conduct of secretarial audit, I hereby report that in my opinion, the company has, during the audit period covering the financial period ended on 31<sup>st</sup> March, 2023 complied with the statutory provisions listed hereunder and also that the Company has proper Board- processes and Compliance-mechanism in place to the extent, in the manner and subject to the reporting made hereinafter:

I have examined the books, papers, minute books, forms and returns filed and other records maintained by **Ultra Wiring Connectivity System Limited** ("the Company") for the financial year ended on 31<sup>st</sup> March, 2023 according to the provisions of:

- (i) The Companies Act, 2013 (the Act) and the rules made thereunder;
- (ii) The Securities Contracts (Regulation) Act, 1956 ('SCRA') and the rules made thereunder;
- (iii) The Depositories Act, 1996 and the Regulations and Bye-laws framed thereunder;
- (iv) Foreign Exchange Management Act, 1999 and the rules and regulations made thereunder to the extent of Foreign Direct Investment, Overseas Direct Investment and External Commercial Borrowings; **N.A**
- (v) The following Regulations and Guidelines prescribed under the Securities and Exchange Board of India Act, 1992 ('SEBI Act'):
  - (a) The Securities and Exchange Board of India (Substantial Acquisition of Shares and Takeovers) Regulation, 2011;
  - (b) The Securities and Exchange Board of India (Prohibition of Insider Trading) Regulations, 2015;
  - (c) The Securities and Exchange Board of India (Issue of Capital and Disclosure Requirements) Regulations, 2018;
  - (d) Securities and Exchange Board of India (Depositories and Participants) Regulations, 2018;
  - (e) The Securities and Exchange Board of India (Share Based Employee Benefits) Regulations, 2014; **N.A**





- (f) The Securities and Exchange Board of India (Issue and Listing of Debt Securities) Regulations, 2008; **N.A.**
- (g) The Securities and Exchange Board of India (Registrars to an Issue and Share Transfer Agents) Regulations, 1993 regarding the Companies Act, and dealing with client;
- (h) The Securities and Exchange Board of India (Delisting of Equity Shares) Regulations, 2009; **N.A.** and
- (i) The Securities and Exchange Board of India (Buyback of Securities) Regulations, 2018; **N.A.**
- (vi) Compliances/ processes/ systems under other applicable Laws to the Company are being verified on the basis of periodic certificate submitted to the Board of Directors of the Company.

**I have also examined compliance with the applicable clauses of the following:**

- (a) Secretarial Standards issued by The Institute of Company Secretaries of India with respect to board and general meetings.
- (b) The Listing Agreements entered into by the Company with National Stock Exchange of India Limited read with the SEBI (Listing Obligations and Disclosure Requirements) Regulations, 2015.

During the period under review the Company has complied with the provisions of the Acts, Rules, Regulations, Guidelines, Standards, etc. mentioned above subject to the following observation:

**Observations:**

**I report that** the Board of Directors of the Company is duly constituted with proper balance of Executive Directors, Non- Executive Directors and Independent Directors. There is no change in the composition of the Board of Directors during the period under review.

Adequate notice is given to all directors to schedule the Board Meetings, agenda and detailed notes on agenda were sent at least seven days in advance, and a system exists for seeking and obtaining further information and clarifications on the agenda items before the meeting and for meaningful participation at the meeting.

Majority decision is carried through were captured and recorded as part of the minutes of the meeting.

**I further report that** there are adequate systems and processes in the Company commensurate with the size and operations of the company to monitor and ensure compliance with applicable laws, rules, regulations and guidelines and Company is in process of reviewing & strengthening the same.

For **Abhishek J & Co.**  
**Company Secretaries**

Sd/-  
CS Abhishek Jain  
M. No. F11233  
C.P No. 16592

Place: Noida  
Date: August 09, 2023  
**UDIN: F011233E000772257**

This report is to be read with our letter of even date which is annexed as “**Annexure A**” and forms an integral part of this report.



**“Annexure A”**

To,  
The Members,  
**Ultra Wiring Connectivity System Limited**

My report of even date is to be read along with this letter.

1. Maintenance of secretarial records, registers is the responsibility of the management of the Company. Our Responsibility is to express an opinion on these secretarial records based on our audit.
2. I have followed the audit practices and processes as were appropriate to obtain reasonable assurance about the correctness of the contents of the secretarial records. The verification was done on test basis to ensure that correct facts are reflected in secretarial records. We believe that the processes and practices, we followed provide a reasonable basis for our opinion.
3. I have not verified the correctness and appropriateness of financial records and Books of Accounts of the Company.
4. Where ever required, we have obtained the Management representation about the compliance of laws, rules and regulation and happening of events etc.
5. The Compliance of the provisions of corporate and other applicable laws, rules, regulations, standards are the responsibility of management. Our examination was limited to the verification of procedures on test basis.
6. The Secretarial Audit Report is neither an assurance as to future viability of the Company nor of the efficacy or effectiveness with which the management has conducted the affairs of the Company.

**For Abhishek J & Co.  
Company Secretaries**

Sd/-  
CS Abhishek Jain  
M. No. : F11233  
C.P No. : 16592

Place: Noida  
Date: August 09, 2023  
**UDIN: F011233E000772257**



**CERTIFICATE OF NON-DISQUALIFICATION OF DIRECTORS**  
[Pursuant to Regulation 34(3) and Schedule V Para C clause (10)(i) of the SEBI (Listing Obligations and Disclosure Requirements) Regulations, 2015]

**The Members of**

**Ultra Wiring Connectivity System Limited**

Plot No. 287, 287-A&B, Sector-59

HSIDC Industrial Area, Faridabad – 121004

I have examined the relevant registers, records, forms, returns and disclosures as received from the Directors of Ultra Wiring Connectivity System Limited having CIN L31300HR2005PLC082730 and registered office at Plot No. 287, 287-A&B, Sector-59 HSIDC Industrial Area, Ballabgarh, Faridabad – 121004 (hereinafter referred to as 'the Company'), produced before me by the Company for the purpose of issuing this Certificate, in accordance with Regulation 34(3) read with Schedule V Para-C Sub clause 10(i) of the SEBI (Listing Obligations and Disclosure Requirements) Regulations, 2015.

In my opinion and to the best of my information and according to the verifications (including Directors Identification Number (DIN) status at the portal [www.mca.gov.in](http://www.mca.gov.in)) as considered necessary and explanations furnished to me by the Company & its officers, I hereby certify that none of the Directors on the Board of the Company as stated below for the Financial Year ending on 31<sup>st</sup> March, 2023 have been debarred or disqualified from being appointed or continuing as Directors of companies by the Securities and Exchange Board of India, Ministry of Corporate Affairs or any such other Statutory Authority.

Name of the Director	PAN and DIN	Original Date of Appointment	Status of DIN as per MCA portal
Sanjay Mathur	PAN- AEAPM7471H, DIN- 00285032	01/06/2005	ACTIVE
Archana Mathur	PAN- AEAPM7470G, DIN- 00285041	01/06/2005	ACTIVE
Aditya Mathur	PAN- AAGPM0790H, DIN- 02109156	01/03/2018	ACTIVE
Rajindarr Ahuja	PAN- ACCPA1729L, DIN- 08069485	15/02/2018	ACTIVE

Ensuring the eligibility of for the appointment / continuity of every Director on the Board is the responsibility of the management of the Company. Our responsibility is to express an opinion on these based on our verification. This certificate is neither an assurance as to the future viability of the Company nor of the efficiency or effectiveness with which the management has conducted the affairs of the Company.

For **Abhishek J & Co.**  
**Company Secretaries**

Sd/-  
**CS Abhishek Jain**  
**FCS No. F11233**  
**C.P No. 16592**

Place: Noida

Date: August 09, 2023

**UDIN: F011233E000772455**



## **ANNEXURE- C**

# **MANAGEMENT DISCUSSION AND ANALYSIS REPORT**

### **GLOBAL ECONOMIC REVIEW**

In the last few years, the world has faced waves of challenges, from the pandemic to the invasion of Ukraine, to the unfolding bank liquidity challenges amidst skittish depositors. The Corona-Delta variant for example poses a challenge to economic recovery by prolonging the pandemic, increasing the need for restrictions and changing consumer attitude.

How we get back to sustainable, long-term growth is the biggest question facing board rooms and political chambers around the world right now. Some of the biggest inflationary fears - widely predicted late last year - have been diluted by more direct, pro-active political action geared especially towards getting rising energy prices down. There are also signs that other commodities and food prices are finally starting to ease – aiding consumers and business owners who've been facing a significant financial squeeze.

The actions taken over the coming months are likely to play a significant role in the pace and nature of the world's economic retrieval. Employment levels should remain robust, even given recent tech layoff announcements– a sign that the rigidity of the labor market faced post-pandemic shows no sign of easing. It's an indication of the complexities the world faces today. Strong employment figures are often held up as an example of flexible market conditions, but they can also reflect the challenges Central Banks are facing as they attempt to juggle wage expectations, tightened credit conditions and the ever-present danger that any shift in the conflict in Ukraine could bring inflation back into the mix. The upside of a strong labor market, combined with relatively strong personal savings among consumers – especially in Europe and the Americas – means we could start to see a return to robust consumer spending, driving a return to slow-but-steady domestic growth in key markets.

### **INDUSTRY STRUCTURE AND DEVELOPMENTS**

India's automotive industry is poised to become the world's third-largest market by 2030, showcasing its dominance in the international heavy vehicles arena. As the industry contributes significantly to India's GDP and manufacturing sector, the nation is also emerging as a leader in electric vehicle (EV) adoption.

India has cemented its place as the largest tractor manufacturer, the second-largest bus manufacturer, and the third-largest heavy truck manufacturer in the world. Currently, the automobile industry contributes 7.1% of India's GDP and accounts for 49% of its manufacturing GDP.

Electric Vehicle (EV) market is expected to grow at a CAGR of 49% between 2022-2030, with





annual sales reaching 10 million units by 2030. The booming EV industry is projected to create 50 million direct and indirect jobs by 2030. A market size of \$50 billion has been identified for EV financing in 2030, equivalent to 80% of the current size of India's retail vehicle finance industry, worth \$60 billion today.

Passenger vehicle sales reached their highest-ever level at 2,504,084 units in FY 2022-23 as of November 2022. The industry is expected to post a growth of 16% in FY23. India's trucking market is predicted to grow more than four-fold by 2050, with the number of trucks increasing from 4 million in 2022 to approximately 17 million by 2050.

A noticeable shift in customer preferences is evident as they gravitate towards larger and more powerful vehicles across all segments. In FY22, utility vehicles (UVs) among passenger vehicles (PVs) accounted for 49% of sales, up from 39% in FY21. Medium & heavy commercial vehicles (M&HCVs) among commercial vehicles (CVs) also increased, making up 33% of sales in FY22 compared to 28% in FY21.

India's \$222 billion automotive industry is anticipated to reach \$300 billion by 2026. Two-wheelers and passenger cars dominate the market, accounting for 76% and 17.4% of the market share, respectively. Small and mid-sized cars lead passenger car sales.

Exports of automobiles increased from 4,134,047 in 2020-21 to 5,617,246 in 2021-22, registering a positive growth of 35.9%. India aims to double its auto industry size to INR 15 lakh crore by the end of 2024. From April 2021 to March 2022, exports of passenger vehicles, commercial vehicles, three-wheelers, and two-wheelers all experienced positive growth compared to the same period last year.

The Indian government has demonstrated its commitment to the industry's growth by increasing the budget allocation of the Faster Adoption and Manufacturing of Hybrid and Electric Vehicles (FAME) II by 78% in the Union Budget 2023. All in all, India's automotive industry is set for an upward trajectory, with strong growth potential in production, sales, and exports. As the nation transitions towards electric vehicles, the industry's economic impact will further expand, solidifying India's position as a global automotive powerhouse.

The ongoing shift in consumer preferences, increasing exports, and government support are key drivers in shaping the future of the industry. As the automotive market continues to evolve, India's strategic focus on innovation, infrastructure development, and sustainable practices will not only boost its economic growth but also position the country as a leading player in the international automotive arena by 2030 and beyond.

#### **PERFORMANCE OF THE COMPANY**

The Company operates in the auto components industry and is engaged in production and



manufacturing of Couplers, Connectors and allied products Blade Fuse and Wiper-Blades for OEMs and Tier 1 manufacturers. The total revenue from operations for the FY 2022-23 is Rs. 4,433.45 Lacs as against 2,945.87 Lacs in the previous year, which shows the considerable increase of 50.49%. Profit before tax of the Company has also grown by 53.82% to Rs. 302.21 Lacs as against 196.46 Lacs in the previous year.

With a vision of sustaining leadership position in manufacturing competitiveness, your Company is working eagerly to increase product portfolio and new applications. Moving to achieve the goal the company is comprehensively and proactively in process to fully utilize the platform developed for manufacturing of products under the segment of “ Commercial Wipers” and “Mini Fuse”.

Our work in the past few years in the area of auto wiper blades has given us the necessary base for potential growth in the existing customer base of wiper blades. The Company’s policy of product innovation and the range of new products already introduced would yield sustainable profitability in the long run.

Started from a Sole Proprietorship Firm established in 1991, we have grown and reached to a to a listed Company in the name of Ultra Wiring Connectivity System Ltd. with an eye towards serving the automotive industry in various segments.

All we know that currently the Company owns 3 Manufacturing Plants, where - Unit 1 & Unit 2 are situated near Delhi in the HSIDC Industrial Area, Faridabad and Unit 3 in ‘Industrial Model Town’ Faridabad. The Company also owns warehouses in Pune to cater the Western markets in India.

We have been in the business of manufacturing of Couplers, Connectors and allied products for OEMs and Tier 1 manufacturers from more than 3 decades and as shared earlier with you all regarding the diversified fields of automotive section such as manufacturing of Blade Fuse and Wiper-Blades which will help us in enhancing our business manifolds.

Presently, the Manufacturing Plants are equipped with 35 Fully Automatic – PLC Controlled and All-Electric Injection Molding Machines that are imported from Japan and Taiwan, supported by a well-equipped in-house Tool-Room, where precision molds and dies are manufactured as per Japanese Standard JASO –D 616-2011 & ISO – 8092.

## **OUTLOOK**

India's automotive industry is poised to become the world's third-largest market by 2030, showcasing its dominance in the international heavy vehicles arena. As the industry contributes significantly to India's GDP and manufacturing sector, the nation is also emerging as a leader in electric vehicle (EV) adoption.

The automotive industry in India is set to expand at a compound annual growth rate (CAGR) of



11.3% till 2027. This growth will most likely occur due to factors like rising disposable income, wide availability of credit and financing options, and growth of population. Furthermore, with the growth of the passenger transport sector and the rise in demand for commercial vehicles, the potential for future growth of India's automotive sector is pretty high.

Apart from this, industry-friendly policies and initiatives by the Indian Government will also play a major role in fueling this development in the years to come.

### **OPPORTUNITIES, THREATS AND RISK FACTORS**

The automobile industry is a highly growing industry, continuously contributing to growth and development. Automobiles give people the opportunity to live, work and travel in ways that were unimaginable a few decades ago. The ease and quality of life improvements the automotive industry brings will only increase the demand for vehicles in the future.

With the advent of E-vehicles & alternative fuel such as Shell gas, CNG, and others, automobile companies are increasing R&D expenditure to drive the next phase of growth through the use of renewable sources of energy which may be solar, wind, etc.

To monitor cost and to manage shrinking margins, automobile companies like Harley, Volvo, Bharat Benz, etc. are building their manufacturing facilities in developing nations like India and China. These nations have a cheap workforce, are high in resources, and are nearer to developed economies. These are ideal conditions for an emerging market.

Whereas over the last 3-4 decades the automobile market has shifted from a demand to a supply market. Availability of a considerable number of variants, stiff competition between them, and a long list of alternatives to choose from has given power to customers to decide whatever they like.

Regulations like excise duty, no entry of outside vehicles in the state, decreasing number of the validity of registration period, and volatility in the fuel prices pose considerable challenges to automobile companies. These factors also affect the growth of the industry.

The employee turnover in the automobile industry is found to be higher when compared to several other sectors. Furthermore, attracting and retaining employees in the automotive industry can be very challenging, especially in the case where competitors are doing what they can to lure the best talent.

But optimization of fuel-driven combustion engines and cost efficiency programs are excellent opportunities for the automobile market. Emerging markets will be the primary growth drivers for a long time to come, and hence fuel-efficient cars are the need of the hour.



The increased availability of data and information, shift in consumer demand, and expanded regulatory requirements for safety and fuel economy will fuel the growth of this industry.

Entering new markets like Asian & BRIC nations will skyrocket the demand for vehicles. Furthermore, other markets are also likely to emerge soon.

The presence of a large number of players in the automobile industry results in intense competition and companies eating into other's share, leaving little scope for new players.

Macroeconomic uncertainty, recession, unemployment, etc. are the economic factors which will daunt the automobile industry for an extended period.

For the consumer segment, fluctuations in fuel prices remains the determining factor for growth. Also, government regulations pertaining to the use of alternative fuels like CNG and Shell gas is also affecting the inventories.

#### **INTERNAL CONTROL SYSTEM AND THEIR ADEQUACY**

The Company has in place a robust internal control system commensurate with its size and operations. The internal controls are aligned with required standards and processes while adhering to local statutory requirements.

The internal controls systems are supported through management reviews, verification by internal and statutory auditors. The internal audit plans are also aligned to the business objectives of the Company which are reviewed and approved by the Audit Committee. Further, the Audit Committee monitors the adequacy and effectiveness of the Company's internal control framework.

#### **HUMAN RESOURCE DEVELOPMENT**

The Company believes that human resource is the most important assets of the organization. It is not shown in the corporate balance sheet, but influences appreciably the growth, progress, profits and the shareholders' values. During the year your company continued its efforts aimed at improving the HR policies and processes to enhance its performance. The vision and mission of the company is to create culture and value system and behavioral skills to insure achievement of its short and long term objectives.

#### **CAUTIONARY STATEMENT:**

Statement made in the Management Discussion and Analysis Report describing the company's objectives, projections, estimates, expectations may be "Forward-looking statements" within the meaning of applicable securities laws and regulations. Actual results could differ from those expressed or implied. Important factors that could make a difference to the Company's operations





include economic conditions affecting demand supply and price conditions in the markets in which the company operates changes in the government regulations, tax laws & other statutes and other incidental factors.

**FOR AND ON BEHALF OF THE BOARD  
ULTRA WIRING CONNECTIVITY SYSTEM LIMITED**

Sd/-  
Sanjay Mathur  
Chairman & Managing Director  
(DIN: 00285032)

Place: Faridabad  
Date: August 21, 2023



**ANNEXURE-D****PARTICULARS OF EMPLOYEE**

Information required under Section 197 of the Companies Act 2013 read with Companies (Appointment and Remuneration of Managerial Personnel) Rules, 2014.

A) The percentage increase in Remuneration of each Director, Chief Financial Officer, Chief Executive Officer and Company Secretary in the Financial year 2022-23 and ratio of remuneration of each key managerial personnel (KMP) against the performance are as under:-

Name of Director(s) & KMP	Designation	Total Remuneration in Rs.	Percentage Increase in Remuneration for the Financial Year 2022-23	Ratio of Remuneration of the director to the median
Mr. Sanjay Mathur	Managing Director	36,00,000.00	0%	22.37 : 1
Mrs. Archana Mathur	Director	36,00,000.00	0%	22.37 : 1
Mr. Aditya Mathur	Independent Director	0	0	0
Mr. Rajindarr Ahuja	Independent Director	0	0	0
Mr. Prabhat Bhatia	Chief Finance Officer	13,82,040.00	10%	8.59 : 1
Mrs. Sarita Chaurasia	Company Secretary	2,66,700.00	5.2%	1.66 : 1

Notes:

- Median remuneration for the financial year 2022-23 is Rs. 13405/- (Rupees Thirteen thousand four hundred five only).
- The number of permanent employees on the rolls of the company is 176 for the year ended March 31, 2023.
- There was 10% increase in median salary of employees during the financial year.
- There was increase in the salaries of employees other than the managerial personnel in the last Financial Year 2022-23.- 10%
- It is affirmed that remuneration paid during the year ended March 31, 2023 is as per the Remuneration Policy of the Company.

**FOR AND ON BEHALF OF THE BOARD  
ULTRA WIRING CONNECTIVITY SYSTEM LIMITED**

Sd/-  
Sanjay Mathur  
Chairman & Managing Director  
(DIN: 00285032)

Place: Faridabad  
Date: August 21, 2023



## **EXECUTIVE DIRECTOR & CHIEF FINANCIAL OFFICER CERTIFICATION**

**(As per regulation 33(2)(a) of SEBI (Listing Obligations and Disclosure Requirements) Regulations, 2015)**

To  
The Board of Directors  
**Ultra Wiring Connectivity System Limited**

We, the undersigned, in our respective capacities as Managing Director and Chief Financial Officer of the Company to the best of our knowledge and belief certify that we have reviewed the Audited financial results of the Company for the year & half year ended March 31, 2023 and based on our knowledge and belief, we certify that these results do not contain any false or misleading statement or figures and do not omit any material fact which may make the statements or figures contained therein misleading.

**FOR AND ON BEHALF OF THE BOARD  
ULTRA WIRING CONNECTIVITY SYSTEM LIMITED**

**Date: May 27, 2023  
Place: Faridabad**

**Sd/-  
Sanjay Mathur  
Managing Director  
DIN: 00285032**

**Sd/-  
Prabhat Bhatia  
Chief Financial Officer  
PAN: AIHPB6099F**



## **INDEPENDENT AUDITOR'S REPORT**

To the members of,  
ULTRA WIRING CONNECTIVITY SYSTEM LIMITED

### **Report on the audit of Financial Statements**

#### **Opinion**

We have audited the accompanying financial statements of ULTRA WIRING CONNECTIVITY SYSTEM LIMITED ("the Company"), which comprise the Balance Sheet as at 31 March 2023, the Statement of Profit and Loss and the Cash Flow Statement for the year then ended, including a summary of significant accounting policies and other explanatory information.

In our opinion and to the best of our information and according to the explanations given to us, the aforesaid financial statements give the information required by the Companies Act, 2013 (the 'Act') in the manner so required and give a true and fair view in conformity with the accounting principles generally accepted in India, of the state of affairs of the Company as at 31 March 2023, and its profit and its cash flows for the year ended on that date.

#### **Basis for Opinion**

We conducted our audit in accordance with the Standards on Auditing specified under Section 143(10) of the Act. Our responsibilities under those standards are further described in the Auditor's Responsibilities for the Audit of the Financial Statements section of our report. We are independent of the Company in accordance with the Code of Ethics issued by the Institute of Chartered Accountants of India ('ICAI') together with the ethical requirements that are relevant to our audit of the financial statements under the provisions of the Act and the rules thereunder, and we have fulfilled our other ethical responsibilities in accordance with these requirements and the Code of Ethics. We believe that the audit evidence we have obtained is sufficient and appropriate to provide a basis for our opinion on the accompanying financial statements.

#### **Key Audit Matters**

Key audit matters are those matters that, in our professional judgment, were of most significance in our audit of the standalone financial statements of the current period. These matters were addressed in the context of our audit of the financial statements as a whole, and in forming our opinion thereon, and we do not provide a separate opinion on these matters.

We have determined the matters described below to be the key audit matters to be communicated in our report.

Key Audit Matter	How our audit addressed the key audit matter
Nil	Not Applicable

#### **Other Information**

The Company's Board of Directors is responsible for the preparation of the other information. The other information comprises the information included in the Management Discussion and Analysis, Board's



Report including Annexures to Board's Report but does not include the financial statements and our auditor's report thereon.

Our opinion on the financial statements does not cover the other information and we do not express any form of assurance conclusion thereon.

In connection with our audit of the financial statements, our responsibility is to read the other information and, in doing so, consider whether the other information is materially inconsistent with the financial statements or our knowledge obtained during the course of our audit or otherwise appears to be materially misstated.

If, based on the work we have performed, we conclude that there is a material misstatement of this other information, we are required to report that fact. We have nothing to report in this regard.

### **Responsibilities of management and those charged with governance for the Financial Statements**

The Company's Board of Directors is responsible for the matters stated in section 134(5) of the Companies Act, 2013 ("the Act") with respect to the preparation of these financial statements that give a true and fair view of the financial position, financial performance and cash flows of the Company in accordance with the accounting principles generally accepted in India, including the accounting Standards specified under section 133 of the Act. This responsibility also includes maintenance of adequate accounting records in accordance with the provisions of the Act for safeguarding of the assets of the Company and for preventing and detecting frauds and other irregularities; selection and application of appropriate accounting policies; making judgments and estimates that are reasonable and prudent; and design, implementation and maintenance of adequate internal financial controls, that were operating effectively for ensuring the accuracy and completeness of the accounting records, relevant to the preparation and presentation of the financial statement that give a true and fair view and are free from material misstatement, whether due to fraud or error.

In preparing the financial statements, management is responsible for assessing the Company's ability to continue as a going concern, disclosing, as applicable, matters related to going concern and using the going concern basis of accounting unless management either intends to liquidate the Company or to cease operations, or has no realistic alternative but to do so.

Those Board of Directors are also responsible for overseeing the Company's financial reporting process.

### **Auditor's Responsibilities for the Audit of the Financial Statements**

Our objectives are to obtain reasonable assurance about whether the financial statements as a whole are free from material misstatement, whether due to fraud or error, and to issue an auditor's report that includes our opinion. Reasonable assurance is a high level of assurance, but is not a guarantee that an audit conducted in accordance with SAs will always detect a material misstatement when it exists.





Misstatements can arise from fraud or error and are considered material if, individually or in the aggregate, they could reasonably be expected to influence the economic decisions of users taken on the basis of these financial statements.

As part of an audit in accordance with Standards on Auditing, we exercise professional judgment and maintain professional skepticism throughout the audit. We also:

- Identify and assess the risks of material misstatement of the financial statements, whether due to fraud or error, design and perform audit procedures responsive to those risks, and obtain audit evidence that is sufficient and appropriate to provide a basis for our opinion. The risk of not detecting a material misstatement resulting from fraud is higher than for one resulting from error, as fraud may involve collusion, forgery, intentional omissions, misrepresentations, or the override of internal control.
- Obtain an understanding of internal control relevant to the audit in order to design audit procedures that are appropriate in the circumstances. Under Section 143(3) (i) of the Act, we are also responsible for explaining our opinion on whether the Company has adequate internal financial controls system in place and the operating effectiveness of such controls.
- Evaluate the appropriateness of accounting policies used and the reasonableness of accounting estimates and related disclosures made by management.
- Conclude on the appropriateness of management's use of the going concern basis of accounting and, based on the audit evidence obtained, whether a material uncertainty exists related to events or conditions that may cast significant doubt on the Company's ability to continue as a going concern. If we conclude that a material uncertainty exists, we are required to draw attention in our auditor's report to the related disclosures in the financial statements or, if such disclosures are inadequate, to modify our opinion. Our conclusions are based on the audit evidence obtained up to the date of our auditor's report. However, future events or conditions may cause the Company to cease to continue as a going concern.
- Evaluate the overall presentation, structure and content of the financial statements, including the disclosures, and whether the financial statements represent the underlying transactions and events in a manner that achieves fair presentation.

1. We communicate with those charged with governance regarding, among other matters, the planned scope and timing of the audit and significant audit findings, including any significant deficiencies in internal control that we identify during our audit.
2. We also provide those charged with governance with a statement that we have complied with relevant ethical requirements regarding independence, and to communicate with them all relationships and other matters that may reasonably be thought to bear on our independence, and where applicable, related safeguards.
3. From the matters communicated with those charged with governance, we determine those matters that were of most significance in the audit of the financial statements of the current period and are therefore the key audit matters. We describe these matters in our auditor's report unless law or



regulation precludes public disclosure about the matter or when, in extremely rare circumstances, we determine that a matter should not be communicated in our report because the adverse consequences of doing so would reasonably be expected to outweigh the public interest benefits of such communication.

### **Report on Other Legal and Regulatory Requirements**

As required by the Companies (Auditor's Report) Order, 2020 (the 'Order') issued by the Central Government of India in terms of Section 143(11) of the Act, we give in the Annexure A, a statement on the matters specified in paragraphs 3 and 4 of the Order, to the extent applicable.

Further to our comments in Annexure B, as required by Section 143(3) of the Act, we report that:

- a) we have sought and obtained all the information and explanations which to the best of our knowledge and belief were necessary for the purpose of our audit;
- b) in our opinion, proper books of account as required by law have been kept by the Company so far as it appears from our examination of those books;
- c) the financial statements dealt with by this report are in agreement with the books of account;
- d) in our opinion, the aforesaid financial statements comply with the accounting standards specified under Section 133 of the Act, read with Rule 7 of the Companies (Accounts) Rules, 2014.
- e) on the basis of the written representations received from the directors and taken on record by the Board of Directors, none of the directors is disqualified as on 31 March 2023 from being appointed as a director in terms of Section 164(2) of the Act;
- f) we have also audited the internal financial controls over financial reporting of the Company as on 31 March 2023 in conjunction with our audit of the financial statements of the Company for the year ended on that date and our report as per Annexure A expressed an unmodified opinion;
- g) with respect to the other matters to be included in the Auditor's Report in accordance with rule 11 of the Companies (Audit and Auditors) Rules, 2014 (as amended), in our opinion and to the best of our information and according to the explanations given to us:
  - i. The Company has disclosed the impact of pending litigations on its financial position in its financial statements – Refer Note 28 to the financial statements.
  - ii. The Company did not have any long term contracts including derivative contracts for which there were any material foreseeable losses.



- iii. there were no amounts required to be transferred to the Investor Education and Protection Fund by the Company during the year ended 31 March 2023;
- iv. (a) The management has represented that, to the best of its knowledge and belief, as disclosed in the notes to the accounts, no funds have been advanced or loaned or invested (either from borrowed funds or share premium or any other sources or kind of funds) by the Company to or in any other person or entity, including foreign entities (“Intermediaries”), with the understanding, whether recorded in writing or otherwise, that the Intermediary shall, whether, directly or indirectly, lend or invest in other persons or entities identified in any manner whatsoever by or on behalf of the Company (“Ultimate Beneficiaries”) or provide any guarantee, security or the like on behalf of the Ultimate Beneficiaries.
- (b) The management has represented that, to the best of its knowledge and belief, as disclosed in the notes to the accounts, no funds have been received by the Company from any person or entity, including foreign entities (“Funding Parties”), with the understanding, whether recorded in writing or otherwise, that the Company shall, whether, directly or indirectly, lend or invest in other persons or entities identified in any manner whatsoever by or on behalf of the Funding Party (“Ultimate Beneficiaries”) or provide any guarantee, security or the like on behalf of the Ultimate Beneficiaries and
- (c) Based on such audit procedures that we considered reasonable and appropriate in the circumstances, nothing has come to our notice that has caused us to believe that the representations under sub-clause (a) and (b) contain any material misstatement.
- v. The company has not declared and paid any dividend during the year in contravention of the provisions of Section 123 of the Companies Act 2013.
- h) The Company has paid/ provided for managerial remuneration in accordance with the requisite approvals mandated by the provisions of Section 197 read with Schedule V to the Act.

**For Sanmarks & Associates**  
**Chartered Accountants**  
**(Firm’s Registration Number: 003343N)**

**Sd/-**  
**Santosh Kumar Agrawal**  
**(Partner)**  
**Membership No. 091127**

**Place: Faridabad**  
**Date: 27/05/2023**

**UDIN : 23091127BGXZUY7754**



## **Annexure A to the Independent Auditor's Report**

**Referred to in paragraph 15(f) of the Independent Auditor's Report of even date to the members of Ultra Wiring Connectivity System Limited, on the financial statements for the year ended 31 March 2023**

**Independent Auditor's Report on the Internal Financial Controls under Clause (i) of Sub-section 3 of Section 143 of the Companies Act, 2013 ("the Act")**

1. We have audited the internal financial controls with reference to financial statements of M/s Ultra Wiring Connectivity System Limited ("the Company") as of 31 March 2023 in conjunction with our audit of the financial statements of the Company for the year ended on that date.

### **Management's Responsibility for Internal Financial Controls**

2. The Company's management and the Board of Directors is responsible for establishing and maintaining internal financial controls based on the internal control over financial reporting criteria established by the Company considering the essential components of internal control stated in the Guidance Note on Audit of Internal Financial Controls over Financial Reporting (the "Guidance Note") issued by the Institute of Chartered Accountants of India (ICAI). These responsibilities include the design, implementation and maintenance of adequate internal financial controls that were operating effectively for ensuring the orderly and efficient conduct of the Company's business, including adherence to Company's policies, the safeguarding of its assets, the prevention and detection of frauds and errors, the accuracy and completeness of the accounting records, and the timely preparation of reliable financial information, as required under the Act.

### **Auditors' Responsibility**

3. Our responsibility is to express an opinion on the Company's internal financial controls with reference to financial statements based on our audit. We conducted our audit in accordance with the Guidance Note and the Standards on Auditing deemed to be prescribed under section 143(10) of the Act to the extent applicable to an audit of internal financial controls, both applicable to an audit of internal financial controls and both issued by the ICAI. Those Standards and the Guidance Note require that we comply with ethical requirements and plan and perform the audit to obtain reasonable assurance about whether adequate internal financial controls with reference to financial statements was established and maintained and if such controls operated effectively in all material respects.
4. Our audit involves performing procedures to obtain audit evidence about the adequacy of the Internal financial controls with reference to financial statements and their operating effectiveness. Our audit of Internal financial controls with reference to financial statements included obtaining an understanding of Internal financial controls with reference to financial statements, assessing the risk that a material weakness exists, and testing and evaluating the design and operating effectiveness of internal control based on the assessed risk. The procedures selected depend on the auditor's judgement, including the assessment of the risks of material misstatement of the financial statements, whether due to fraud or error.



5. We believe that the audit evidence we have obtained is sufficient and appropriate to provide a basis for our audit opinion on the Company's Internal financial controls with reference to financial statements.

6. **Meaning of Internal Financial Controls over Financial Reporting**

A Company's Internal financial controls with reference to financial statements is a process designed to provide reasonable assurance regarding the reliability of financial reporting and the preparation of financial statements for external purposes in accordance with generally accepted accounting principles. A Company's Internal financial controls with reference to financial statements includes those policies and procedures that (1) pertain to the maintenance of records that, in reasonable detail, accurately and fairly reflect the transactions and dispositions of the assets of the Company; (2) provide reasonable assurance that transactions are recorded as necessary to permit preparation of financial statements in accordance with generally accepted accounting principles, and that receipts and expenditures of the Company are being made only in accordance with authorisations of management and directors of the Company; and (3) provide reasonable assurance regarding prevention or timely detection of unauthorised acquisition, use, or disposition of the Company's assets that could have a material effect on the financial statements.

7. **Inherent Limitations of Internal Financial Controls with Reference to Financial Statements**

Because of the inherent limitations of internal financial controls with reference to standalone financial statements, including the possibility of collusion or improper management override of controls, material misstatements due to error or fraud may occur and not be detected. Also, projections of any evaluation of the internal financial controls with reference to standalone financial statements to future periods are subject to the risk that the internal financial controls with reference to standalone financial statements may become inadequate because of changes in conditions, or that the degree of compliance with the policies or procedures may deteriorate.

8. **Opinion**

In our opinion, to the best of our information and according to the explanations given to us, the Company has, in all material respects, an adequate internal financial controls system over financial reporting and such internal financial controls over financial reporting were operating effectively as at March 31, 2023, based on the criteria for internal financial control over financial reporting established by the Company considering the essential components of internal control stated in the Guidance Note on Audit of Internal Financial Controls Over Financial Reporting issued by the ICAI.

**For Sanmarks & Associates**  
**Chartered Accountants**  
**(Firm's Registration Number: 003343N)**

**Sd/-**  
**Santosh Kumar Agrawal**  
**(Partner)**  
**Membership No. 091127**  
**Place: Faridabad**  
**Date: 27/05/2023**  
**UDIN : 23091127BGXZUY7754**





## **Annexure B to the Independent Auditor's Report**

**Referred to in paragraph 14 of the Independent Auditor's Report of even date to the members of Ultra Wiring Connectivity System Limited, on the financial statements for the year ended 31 March 2023**

- (i) (a) The Company has maintained proper records showing full particulars, including quantitative details and situation of property, plant and equipment.
- (b) The Company has a regular program of physical verification of its fixed assets by which fixed assets are verified every year. In accordance with this program, the fixed assets were verified during the year and no material discrepancies were noticed on such verification. In our opinion, this periodicity of physical verification is reasonable having regard to the size of the Company and the nature of its assets.
- (c) According to the information and explanations given to us, the title deeds of immovable properties, as disclosed in Note 13 to the financial statements, are held in the name of the company.
- (d) The Company has not revalued its Property, Plant and Equipment during the year. Consequently, the question of our commenting on whether the revaluation is based on the valuation by a Registered Valuer, or specifying the amount of change, if the change is 10% or more in the aggregate of the net carrying value of each class of Property, Plant and Equipment does not arise.
- (e) Based on the information and explanations furnished to us, no proceedings have been initiated or are pending against the Company for holding benami property under the Prohibition of Benami Property Transactions Act, 1988 (as amended in 2016) (formerly the Benami Transactions (Prohibition) Act, 1988 (45 of 1988) and Rules made there under, and therefore the question of our commenting on whether the Company has appropriately disclosed the details in its financial statements does not arise.
- (ii) (a) The physical verification of inventory has been conducted at reasonable intervals by the Management during the year and, in our opinion, the coverage and procedure of such verification by Management is appropriate. There was no inventory lying with third parties as at year end. The discrepancies noticed on physical verification of inventory as compared to book records were not 10% or more in aggregate for each class of inventory.
- (b) During the year, the Company was not sanctioned working capital limits in excess of Rs. 5 crore, in aggregate, from banks on the basis of security of current assets and therefore the question of our commenting on whether the Company has filed quarterly returns or statements with such banks, which are in agreement with the unaudited books of account does not arise.



- (iii) The Company has not made investments in any company during the year. The Company has not granted secured / unsecured loans/advances in nature of loans, stood guarantor, or provided security to any parties. Therefore, the reporting under clauses (iii)(a), (iii)(b), (iii)(c), (iii) (d), (iii)(e) and (iii) (f) of the Order are not applicable to the Company.
- (iv) The Company has not granted any loans, or provided any guarantees or security to the parties covered under Section 185 of the Act. Further, in our opinion, and according to the information and explanations given to us, the Company has not made any investments during the year and thus, question of complying with the provisions of Section 186 of the Companies Act, 2013 in respect of the investments made by it does not arise and the Company has not provided any loans, guarantees or security to the parties covered under Section 186 of the Act.

The Company has not accepted any deposits or amounts, which are deemed deposits within the meaning of Sections 73, 74, 75 and 76 of the Act and the Rules framed there under to the extent notified.

- (v) In our opinion, the company is not required to maintain the cost records u/s 148(1) of the Companies Act for any of its products as the company is classified under “Small” category as per Section 9(7) of the MSMED Act, 2006.
- (vi) (a) According to the information and explanations given to us and the records of the Company examined by us, in our opinion, the Company is regular in depositing the undisputed statutory dues, including goods and services tax, provident fund, employees’ state insurance, income tax, duty of customs and other material statutory dues, as applicable, with the appropriate authorities.
- (b) According to the information and explanations given to us and the records of the Company examined by us, there are no statutory dues of provident fund, employees’ state insurance, GST, excise and VAT , which have not been deposited on account of any dispute. The particulars of other statutory dues referred to in subclause (a) as at March 31, 2023 which have not been deposited on account of a dispute, are as follows:

Name of the Statute	Nature of dues	Amount of demand without netting off amount paid under protest (Rs. in ‘000)	Amount paid under protest (Rs. in ‘000)	Period to which the demand relates (Financial Year)	Forum where dispute is pending
Income Tax Act, 1961	Assessed at wrong rate of tax by the assessing officer	1675.78	0.00	2017-18	CIT(A), Delhi



The above amounts contain interest and penalty where included in the order issued by the department to the Company.

- (viii) According to the information and explanations given to us and the records of the Company examined by us, there are no transactions in the books of account that has been surrendered or disclosed as income during the year in the tax assessments under the Income Tax Act, 1961, that has not been recorded in the books of account.
- (ix) (a) According to the records of the Company examined by us and the information and explanations given to us, the Company has not defaulted in repayment of loans or other borrowings or in the payment of interest to any lender during the year.
- (b) According to the information and explanations given to us and on the basis of our audit procedures, we report that the Company has not been declared Willful Defaulter by any bank or financial institution or government or any government authority.
- (c) In our opinion, and according to the information and explanations given to us, the term loans taken during the year have been applied for the purposes for which they were obtained. In respect of the term loans which were taken in the previous year, those were applied for the purpose for which the loans were obtained. (Also refer Note 5(k) to the standalone financial statements).
- (d) According to the information and explanations given to us, and the procedures performed by us, and on an overall examination of the financial statements of the Company, we report that no funds raised on shortterm basis have been used for long-term purposes by the Company.
- (e) The company has no subsidiaries, therefore reporting under clauses (ix)e and (ix)f are not applicable to it.
- (x) (a) The Company has not raised any money by way of initial public offer or further public offer (including debt instruments) during the year. Accordingly, the reporting under clause 3(x)(a) of the Order is not applicable to the Company.
- (b) The Company has not made any preferential allotment or private placement of shares or fully or partially or optionally convertible debentures during the year. Accordingly, the reporting under clause 3(x)(b) of the Order is not applicable to the Company.
- (xi) (a) During the course of our examination of the books and records of the Company, carried out in accordance with the generally accepted auditing practices in India, and according to the information and explanations given to us, we have neither come across any instance of material fraud by the Company or on the Company, noticed or reported during the year, nor have we been informed of any such case by the Management.



(b) During the course of our examination of the books and records of the Company, carried out in accordance with the generally accepted auditing practices in India, and according to the information and explanations given to us, a report under Section 143(12) of the Act in Form ADT-4 as prescribed under rule 13 of Companies (Audit and Auditors) Rules, 2014 was not required to be filed with the Central Government. Accordingly, the reporting under clause 3(xi)(b) of the Order is not applicable to the Company.

(c) During the course of our examination of the books and records of the Company, carried out in accordance with the generally accepted auditing practices in India, and according to the information and explanations given to us, the Company has not received any whistle-blower complaints during the year. Accordingly, reporting under this clause is not required for the company.

(xii) As the Company is not a Nidhi Company and the Nidhi Rules, 2014 are not applicable to it, the reporting under clause 3(xii) of the Order is not applicable to the Company.

(xiii) The Company has entered into transactions with related parties in compliance with the provisions of Sections 177 and 188 of the Act. The details of such related party transactions have been disclosed in the standalone financial statements as required under Indian Accounting Standard 24, "Related Party Disclosures" specified under Section 133 of the Act.

(xiv) (a) In our opinion and according to the information and explanation given to us, the Company has an internal audit system commensurate with the size and nature of its business.

(b) The reports of the Internal Auditor for the period under audit have been considered by us.

(xv) The Company has not entered into any non-cash transactions with its directors or persons connected with him. Accordingly, the reporting on compliance with the provisions of Section 192 of the Act under clause 3(xv) of the Order is not applicable to the Company.

(xvi) (a) The Company is not required to be registered under Section 45-IA of the Reserve Bank of India Act, 1934. Accordingly, the reporting under clause 3(xvi)(a) of the Order is not applicable to the Company.

(b) The Company has not conducted non-banking financial / housing finance activities during the year. Accordingly, the reporting under clause 3(xvi)(b) of the Order is not applicable to the Company.

(c) The Company is not a Core Investment Company (CIC) as defined in the regulations made by the Reserve Bank of India. Accordingly, the reporting under Clause 3(xvi) (c) of the Order is not applicable to the Company.



- (d) Based on the information and explanations provided by the management of the Company, the Group does not have any CICs, which are part of the Group. We have not, however, separately evaluated whether the information provided by the management is accurate and complete. Accordingly, the reporting under clause 3(xvi)(d) of the Order is not applicable to the Company.
- (xvii) The Company has not incurred any cash losses in the financial year or in the immediately preceding financial year.
- (xviii) There has been no resignation of the statutory auditors during the year and accordingly the reporting under Clause (xviii) is not applicable.
- (xix) According to the information and explanations given to us and on the basis of the financial ratios (Also refer Note 33 to the financial statements), ageing and expected dates of realisation of financial assets and payment of financial liabilities, other information accompanying the financial statements, our knowledge of the Board of Directors and management plans and based on our examination of the evidence supporting the assumptions, nothing has come to our attention, which causes us to believe that any material uncertainty exists as on the date of the audit report that Company is not capable of meeting its liabilities existing at the date of balance sheet as and when they fall due within a period of one year from the balance sheet date. We, however, state that this is not an assurance as to the future viability of the Company. We further state that our reporting is based on the facts up to the date of the audit report and we neither give any guarantee nor any assurance that all liabilities falling due within a period of one year from the balance sheet date, will get discharged by the Company as and when they fall due.
- (xx) The provisions of CSR are not applicable to the company as it has not crossed the threshold limits defined for same under Section 135 of the Companies Act, 2013. Accordingly, reporting under clause 3(xx)(a) and 3(xx)(b) are not applicable to the company.
- (xxi) The reporting under clause 3(xxi) of the Order is not applicable in respect of audit of Standalone Financial Statements. Accordingly, no comment in respect of the said clause has been included in this report.

**For Sanmarks & Associates**  
**Chartered Accountants**  
**(Firm's Registration Number: 003343N)**

**Sd/-**  
**Santosh Kumar Agrawal**  
**(Partner)**  
**Membership No. 091127**

**Place: Faridabad**  
**Date: 27/05/2023**  
**UDIN : 23091127BGXZUY7754**





**ULTRA WIRING CONNECTIVITY SYSTEM LIMITED****BALANCE SHEET AS AT 31.03.2023****CIN - L31300HR2005PLC082730****(Amount In Rs.Thousands)**

	<b>PARTICULARS</b>	<b>NOTE NO.</b>	<b>As At 31-03-2023</b>	<b>As At 31-03-2022</b>
<b>I</b>	<b><u>EQUITY &amp; LIABILITIES</u></b>		-	-
<b>(1)</b>	<b>SHAREHOLDERS' FUND</b>			
	(a) SHARE CAPITAL	<b>3</b>	52,035.71	52,035.71
	(b) RESERVES AND SURPLUS	<b>4</b>	120,717.16	98,465.01
<b>(2)</b>	<b>SHARE APPLICATION MONEY PENDING ALLOTMENT</b>		0.00	0.00
<b>(3)</b>	<b>NON- CURRENT LIABILITIES</b>			
	(a) LONG TERM BORROWINGS	<b>5</b>	42,843.76	32,997.07
	(b) DEFERRED TAX LIABILITIES (NET)	<b>6</b>	8,330.74	6,552.84
	(c) OTHER LONG TERM LIABILITES	<b>7</b>	400.00	1,000.00
	(c ) LONG TERM PROVISIONS	<b>8</b>	2,770.77	2,268.43
<b>(4)</b>	<b>CURRENT LIABILITIES</b>			
	(a) SHORT TERM BORROWINGS	<b>9</b>	8,308.32	5,297.26
	(b) TRADE PAYABLES	<b>10</b>		
	i) Total Outstanding dues of MSMEs		13,769.12	2,380.91
	ii) Total Outstanding dues of creditors other than MSMEs		99,270.06	90,914.50
	(c ) OTHER CURRENT LIABILITIES	<b>11</b>	10,720.86	9,474.12
	(d) SHORT TERM PROVISIONS	<b>12</b>	1.20	848.84
	<b>TOTAL</b>		<b>359,167.69</b>	<b>302,234.69</b>
<b>II</b>	<b><u>ASSETS</u></b>			
<b>(1)</b>	<b>NON - CURRENT ASSETS</b>			
	(a) PROPERTY, PLANT AND EQUIPMENT & INTANGIBLE ASSETS			
	(i) PROPERTY, PLANT & EQUIPMENT	<b>13</b>	127,519.72	105,343.92
	(ii) INTANGIBLE ASSETS		0.00	0.00
	(iii) CAPITAL WORK IN PROGRESS		0.00	0.00
	(iv) INTANGIBLE ASSETS UNDER DEVELOPMENT		0.00	0.00
	(b) NON CURRENT INVESTMENTS		0.00	0.00
	(c ) DEFERRED TAX ASSETS (NET)		0.00	0.00
	(d) LONG TERM LOANS AND ADVANCES		0.00	0.00
	(e) OTHER NON CURRENT ASSETS	<b>14</b>	3,804.66	3,405.24
<b>(2)</b>	<b>CURRENT ASSETS</b>			
	(a) CURRENT INVESTMENTS		0.00	0.00
	(b) INVENTORIES	<b>15</b>	19,028.67	24,101.08
	(c)TRADE RECEIVABLES	<b>16</b>	181,193.77	142,784.94
	(d) CASH AND CASH EQUIVALENTS	<b>17</b>	5,371.80	6,730.32
	(e) SHORT TERM LOANS AND ADVANCES	<b>18</b>	12,064.35	12,984.82
	(f) OTHER CURRENT ASSETS	<b>19</b>	10,184.74	6,884.38



	<b>TOTAL</b>		<b>359,167.69</b>	<b>302,234.69</b>
<b>Corporate Information</b>		<b>1</b>		
<b>Significant accounting policies</b>		<b>2</b>		
<b>Other Notes on accounts</b>		<b>28 - 39</b>		
<b>As per our Report of even date For SANMARKS &amp; ASSOCIATES CHARTERED ACCOUNTANTS FRN : 003343N</b>			<b>For and On behalf of Board of Directors</b>	
			<b>Sd/- (SANJAY MATHUR) Managing Director DIN: 00285032</b>	<b>Sd/- (ARCHANA MATHUR) Director DIN: 00285041</b>
<b>SANTOSH KUMAR AGRAWAL (PARTNER), M. NO. 091127</b>				
<b>PLACE : FARIDABAD DATED : 27/05/2023</b>			<b>Sd/- (PRABHAT BHATIA) Chief Financial Officer</b>	<b>Sd/- (SARITA CHAURASIA) Company Secretary</b>



**ULTRA WIRING CONNECTIVITY SYSTEM LIMITED**  
**STATEMENT OF PROFIT & LOSS FOR THE YEAR ENDED 31-03-2023**  
**CIN - L31300HR2005PLC082730**

(Amount In Rs.Thousands)

	PARTICULARS	NOTE NO.	As At 31-03-2023	As At 31-03-2022
I.	<b>INCOME</b> REVENUE FROM OPERATIONS	20	443,345.00	294,586.66
II.	OTHER INCOME	21	1,043.67	2,044.02
III.	<b>TOTAL INCOME (I+II)</b>		<b>444,388.67</b>	<b>296,630.68</b>
IV.	<b>EXPENSES</b> COSTS OF MATERIAL CONSUMED	22	284,947.07	191,345.63
	CHANGES IN INVENTORIES OF FINISHED GOODS / WIP	22A	1,426.43	(2,902.00)
	EMPLOYEE BENEFITS EXPENSE	23	46,312.78	32,610.01
	FINANCE COST	24	4,850.19	2,899.04
	DEPRECIATION AND AMORTISATION EXPENSE	25	9,215.77	6,578.35
	OTHER EXPENSES	26	67,415.63	46,454.35
	<b>TOTAL EXPENSES</b>		<b>414,167.87</b>	<b>276,985.40</b>
V	<b>PROFIT BEFORE TAX</b>		<b>30,220.80</b>	<b>19,645.29</b>
VI	TAX EXPENSE: (1) CURRENT TAX		6,190.75	3,800.00
	(2) TAX PROVISION FOR EARLIER YEARS		0.00	0.00
	(3) DEFERRED TAX		1,777.90	815.12
VII	<b>PROFIT/(LOSS) FOR THE PERIOD</b>		<b>22,252.15</b>	<b>15,030.17</b>
	<b>Basic &amp; Diluted Earning per Equity Share (Face Value of Rs. 10/- each)</b>			
	(1) BASIC EPS (Rs.)	27	4.28	2.89
	(2) DILUTED EPS (Rs.)	27	4.28	2.89

Corporate Information

Significant accounting policies

Other Notes on accounts

1

2

28-39

As per our Report of even date  
For SANMARKS & ASSOCIATES  
CHARTERED ACCOUNTANTS  
FRN : 003343N

For and On behalf of Board of Directors

SANTOSH KUMAR AGRAWAL  
(PARTNER), M. NO. 091127  
PLACE : FARIDABAD  
DATED : 27/05/2023

Sd/-  
(SANJAY MATHUR)  
Managing Director  
DIN: 00285032

Sd/-  
(ARCHANA MATHUR)  
Director  
DIN: 00285041

Sd/-  
(PRABHAT BHATIA)  
Chief Financial Officer

Sd/-  
(SARITA CHAURASIA)  
Company Secretary

**ULTRA**

**ULTRA WIRING CONNECTIVITY SYSTEM LIMITED**  
**CASH FLOW STATEMENT FOR THE YEAR ENDED 31-03-2023**  
**CIN - L31300HR2005PLC082730**

(Amount In Rs. Thousands)

CASH FLOW STATEMENT FOR	YEAR ENDED 31-03-2023	YEAR ENDED 31-03-2022
<b>CASH FLOWS FROM OPERATING ACTIVITIES</b>		
Net Profit before tax & extra-ordinary items	30,220.80	19,645.29
Adjustments for:		
Depreciation	9,215.77	6,578.35
Interest Received	-472.38	-609.46
Rent Received	-242.00	-1,419.00
Interest Paid	4,850.19	2,899.04
<b>Operating Profit before Working Capital Changes</b>	<b>43,572.38</b>	<b>27,094.22</b>
Adjustment for:		
Trade receivables	-38,408.83	-10,913.76
Inventories	5,072.42	-7,699.47
Loans and advances and other assets	-2,779.31	-1,156.48
Trade Payables	19,743.77	7,212.36
Other Liabilities and Provisions	301.43	-15.24
<b>Cash Generated / (used) from Operations</b>	<b>27,501.86</b>	<b>14,521.63</b>
Income tax Refund / (Paid) during the year	-6,190.75	-3,800.00
<b>NET CASH FLOWS FROM OPERATING ACTIVITIES</b>	<b>21,311.11</b>	<b>10,721.63</b>
<b>CASH FLOWS FROM INVESTING ACTIVITIES</b>		
Purchase of Fixed Assets & Capital Work in Progress	-31,391.57	-7,212.94
Interest Received	472.38	609.46
Rent Received	242.00	1,419.00
<b>NET CASH FLOWS FROM INVESTING ACTIVITIES</b>	<b>-30,677.19</b>	<b>-5,184.48</b>
<b>CASH FLOWS FROM FINANCING ACTIVITIES</b>		
Proceeds from Borrowings	18,155.01	0.00
Repayment of Borrowings	-5,297.26	-5,628.06
Dividend Paid	0.00	0.00
Interest Paid	-4,850.19	-2,899.04
<b>NET CASH FLOWS FROM FINANCING ACTIVITIES</b>	<b>8,007.56</b>	<b>-8,527.11</b>
<b>NET INCREASE/(DECREASE) IN CASH AND CASH EQUIVALENTS</b>	<b>-1,358.52</b>	<b>-2,989.96</b>
CASH AND CASH EQUIVALENTS AT THE BEGINNING OF THE PERIOD	6,730.32	9,720.28
<b>CASH AND CASH EQUIVALENTS AT THE END OF THE PERIOD</b>	<b>5,371.80</b>	<b>6,730.32</b>

*As per our Report of even date*  
**For SANMARKS & ASSOCIATES**  
**CHARTERED ACCOUNTANTS**  
**FRN : 003343N**

**SANTOSH KUMAR AGRAWAL**  
**(PARTNER), M. NO. 091127**

**PLACE : FARIDABAD**  
**DATED : 27/05/2023**

**For and on behalf of the Board of Directors**

Sd/-  
**(SANJAY MATHUR)**  
**Managing Director**  
**DIN: 00285032**

Sd/-  
**(ARCHANA MATHUR)**  
**Director**  
**DIN: 00285041**

Sd/-  
**(PRABHAT BHATIA)**  
**Chief Financial Officer**

Sd/-  
**(SARITACHAURASIA)**  
**Company Secretary**



## NOTE

### 1 CORPORATE INFORMATION

Ultra Wiring Connectivity System Limited is a public limited company domiciled in India and incorporated on 01st June 2005 under the provisions of the Companies Act, 1956 with its registered office being at Plot No. 287, 287 A & B, HSIIDC Industrial Estate, Sector 59, Faridabad. The company was originally registered as a private limited company. The company went on board in the month of September 2018 and is currently listed at the SME (Emerge) platform of National Stock Exchange of India. The company is engaged in the manufacturing & selling of wipers, connectors, cable tie clips and allied components. The company caters to domestic market mainly with few exports.

The company currently has three manufacturing facilities both of which are located in the Faridabad District of Haryana.

### 2 SIGNIFICANT ACCOUNTING POLICIES

#### 1 BASIS OF PREPARATION OF FINANCIAL STATEMENTS (AS-1)

These financial statements have been prepared to comply with Accounting Principles Generally accepted in India (Indian GAAP), the Accounting Standards referred to in Section 133 of the Companies Act, 2013 read with rule 7 of Company (Accounts) Rules, 2014 to the extent applicable.

The financial statements are prepared on accrual basis under the historical cost convention. Accounting Policies have been consistently applied by the company and are consistent with those used in the previous year. The financial statements are presented in Indian rupees.

#### 2 USE OF ESTIMATES

The preparation of financial statements in conformity with Indian GAAP requires judgements, estimates and assumptions to be made that affect the reported amount of assets and liabilities, disclosure of contingent liabilities on the date of the financial statements and the reported amount of revenues and expenses during the reporting period. Difference between the actual results and estimates are recognised in the period in which the results are known/materialised.

#### 3 REVENUE RECOGNITION (AS-9)

Sales are recognised, net of returns and trade discounts, on transfer of significant risks and rewards of ownership to the buyer, which generally coincides with the delivery of goods to customers. Sales exclude Goods and Service Tax.

#### 4 PROPERTY, PLANT AND EQUIPMENT (AS-10)

Tangible Fixed assets (Except Land) are stated at cost of acquisition less accumulated depreciation and any accumulated impairment losses. Cost comprises of the purchase price, net changes on foreign exchange contracts, adjustments arising from exchange rate variations attributable and attributable cost of bringing the asset to working condition for its intended use.





## **5 ACCOUNTING FOR GOVERNMENT GRANTS**

Government grants are recognised when there is a reasonable assurance as to its receipt and that the conditions attached thereto shall be complied with. Government grants related to capital investments are reduced from the gross value of fixed assets and such grants relating to expenses are reduced from the related expense head.

## **6 DEPRECIATION**

Depreciation on fixed assets is provided to the extent of depreciable amount on the Straightline Method (SLM) on the basis of useful life of the fixed assets. The company has adopted useful life of the Fixed Assets as prescribed in Schedule II of the Companies Act, 2013.

## **7 INVENTORIES VALUATION (AS-2)**

Cost of inventory comprise cost of purchase and includes all charges in bringing the goods to the point of sale, including octroi and other levies, transit insurance and receiving charges.

Raw Material is valued at cost or Net Realizable Value whichever is less. The cost is determined mostly on FIFO basis.

WIP valued at cost of production, depending upon its level of completion.

Finished Goods valued at Cost of Production or Net Realizable Value whichever is less.

## **8 EMPLOYEE BENEFITS(AS-15)**

Retirement benefits in the form of Provident Fund, which are defined contribution plans, are accounted for on accrual basis and charged to the Statement of Profit & Loss of the year.

The benefit in the form of Leave Encashment is a non accumulating short term compensated absences. It is accounted in the year when absences occur and charged to Statement of Profit & Loss of the year.

Retirement benefits in the form of Gratuity is accounted for in the accounts on the basis of estimate by the management and not on actuarial valuation.

## **9 BORROWING COSTS (AS-16)**

Borrowing costs that are attributable to the acquisition of qualifying assets are capitalised as part of the cost of such assets. A qualifying asset is one that necessarily takes substantial period of time to get ready for intended use. All other borrowing costs are charged to revenue.

## **10 ACCOUNTING FOR TAXES ON INCOME (AS-22)**

Company has followed accounting standard AS 22 for determination of tax expense in the accounts. Tax provision for current tax is made for income tax, based on the tax liability computed, after considering tax allowances and exemptions.

Deferred tax assets and liabilities are measured using the tax rates and tax law that have been enacted or



substantively enacted by the Balance Sheet date.

#### **11 PROVISIONS, CONTINGENT LIABILITIES AND CONTINGENT ASSETS (AS-29)**

The company recognizes as Provision, the liabilities being present obligation arising out of past events, the settlement of which is expected to result in an outflow of resources and which can be measured only by using a substantial degree of estimation.

When there is a possible obligation or a present obligation in respect of which the likelihood of outflow of resources is remote, no provision or disclosure is made.

Contingent assets are neither recognised nor disclosed.

#### **13 CASH AND CASH EQUIVALENTS**

For the purpose of Cash Flow Statement, cash and cash equivalents include cash in hand and demand deposits with banks.

#### **14 EARNINGS PER SHARE (AS-20)**

Basic earnings per share is computed by dividing the profit / (loss) after tax (including the post tax effect of extraordinary items, if any) by the weighted average number of equity shares outstanding during the year. Diluted EPS is computed using weighted average number of equity and dilutive equity equivalent shares outstanding during the year, except where results would be anti-dilutive.

#### **15 FOREIGN CURRENCY TRANSACTIONS (AS-11)**

- i. Transactions denominated in foreign currencies are recorded at the exchange rate prevailing on the date of the transaction.
- ii. Monetary items denominated in foreign currency at the end of year are reported using the closing rate.
- iii. Non monetary foreign currency items are carried at cost using the exchange rate at the date of transaction.
- iv. Any Gain or Loss on account of exchange difference either on settlement or on translation is recognized in the Statement of Profit & Loss except in case they relate to acquisition of fixed assets, they are adjusted to the carrying cost of such assets.

#### **16 SEGMENT (AS-17)**

The company operates in a single segment, no segment reporting is required by the company as of now.



**ULTRA WIRING CONNECTIVITY SYSTEM LIMITED**  
**NOTES TO FINANCIAL STATEMENTS FOR PERIOD ENDED 31ST MARCH, 2023**  
**CIN - L31300HR2005PLC082730**

**(Amount In Rs.Thousands)**

<b><u>PARTICULARS</u></b>	<b><u>As At 31-03-2023</u></b>		<b><u>As At 31-03-2022</u></b>		
<b>3</b>	<b><u>SHARE CAPITAL</u></b>				
<b>a.</b>	<b>AUTHORISED SHARE CAPITAL</b>				
	5500000 (Previous Year 5500000) Equity Shares of Rs.10/- each	55,000.00		55,000.00	
<b>b.</b>	<b>ISSUED, SUBSCRIBED AND FULLY PAID UP SHARES</b>				
	5203571 (Previous year 5203571) Equity Shares of Rs. 10/- Each	52,035.71		52,035.71	
		<u>52,035.71</u>		<u>52,035.71</u>	
<b>c.</b>	<b>Reconciliation of the shares outstanding at the beginning and at the end of the period</b>				
	<b>Equity Shares</b>	<b><u>As At 31-03-2023</u></b>		<b><u>As At 31-03-2022</u></b>	
		<b>No. of shares</b>	<b>Amount in Rs. '000</b>	<b>No. of shares</b>	<b>Amount in Rs. '000</b>
	At the beginning of the period	5203571	52,035.71	5203571	52,035.71
	Issued during the period	0	0.00	0	0.00
	Outstanding at the end of the period	<u>5203571</u>	<u>52,035.71</u>	<u>5203571</u>	<u>52,035.71</u>

**d) Shareholding of promoters**

S.No	Shares held by promoters at the end of the year	As at 31 March, 2023		As at 31 March, 2022		% change during the year
		No. of equity shares	% of Total shares	No. of equity shares	% of Total shares	
1	Shri Sanjay Mathur (as Managing Director of the company)	1,304,600	25.07%	1,304,600	25.07%	0.00%
2	Smt. Archana Mathur (as Director of the company)	2,522,916	48.48%	2,522,916	48.48%	0.00%
	<b>Total</b>	<b>3,827,516</b>	<b>73.56%</b>	<b>3,827,516</b>	<b>73.56%</b>	

**e. Terms/ Rights attached to Equity Shares**

The Company has only one class of issued share capital i.e. equity shares having a par value of Rs.10/- per share (March 31,2022 : Rs.10/- per share). Each holder of equity shares is entitled to one vote per share. The Company declares and pays dividend in Indian rupees. The dividend proposed by the Board of Directors (if any) is subject to the approval of the shareholders in the ensuing Annual General Meeting.

In the event of liquidation of the company, the holders of equity shares will be entitled to receive remaining assets of the company, after distribution of all preferential amounts. The distribution will be in proportion to the number of equity shares held by the equity shareholders.



f. **Details of shareholders holding more than 5% shares in the company:**

Name of the Shareholder	<u>As At 31-03-2023</u>		<u>As At 31-03-2022</u>	
	No. of shares	% holding	No. of shares	% holding
Sanjay Mathur	1304600	25.07	1304600	25.07
Archana mathur	2522916	48.48	2522916	48.48

g. The company has not issued any shares for consideration other than in cash during a period of five years immediately preceding the reporting date.

**Details of bonus shares issued by the company during a period of five years immediately preceding the reporting date:**

Date of allotment	Class of equity shares	Aggregate Number of shares allotted as fully paid up bonus shares
16th Feb, 2018	Equity Shares of Rs. 10/- each	3479610

The company has not bought back its shares during a period of five years immediately preceding the reporting date.

4 **RESERVES & SURPLUS**

	<u>As At 31-03-2023</u>	<u>As At 31-03-2022</u>
<b>a. <u>Securities Premium</u></b>		
At the beginning of the period	34,400.00	34,400.00
Add: Received during the year	0.00	0.00
Less: Adjustment on account of Bonus Issue	0.00	0.00
At the end of the period	<u>34,400.00</u>	<u>34,400.00</u>
<b>b. <u>Surplus in the statement of Profit &amp; Loss</u></b>		
At the beginning of the period	64,065.01	49,034.85
Add: Profit for the period	22,252.15	15,030.16
Less: Dividend Paid	0.00	0.00
Net Surplus in the statement of Profit & Loss	<u>86,317.16</u>	<u>64,065.01</u>
<b>Total Reserves &amp; Surplus</b>	<u><u>120,717.16</u></u>	<u><u>98,465.01</u></u>

**Note: - 1. Securities premium is used to record the premium on issue of shares. The reserve can be utilised only for limited purposes such as issuance of bonus shares in accordance with the provisions of the Companies Act, 2013.**

**Note: - 2. Surplus in the statement of Profit and Loss are profits that the Company has earned till date less transfer to Reserves (if any) ,dividend or other distribution or transaction with shareholders.**

	<u>As At 31-03-2023</u>	<u>As At 31-03-2022</u>
5 <b><u>LONG TERM BORROWINGS</u></b>		
a) <b><u>Term Loans</u></b>		
From Banks (Secured) {refer note (a) to (d) below}	24,652.08	11,794.33



Less: Current maturities of long term borrowings (refer note 9)	8,308.32	5,297.26
Non Current portion	<u>16,343.76</u>	<u>6,497.07</u>
<b>b) <u>Loans and Advances from related parties</u></b>		
From Directors (Unsecured) - Refer note on related party disclosures	26,500.00	26,500.00
	<u><b>42,843.76</b></u>	<u><b>32,997.07</b></u>

**Notes:-**

- (a) The company has availed secured auto loan of Rs 2010000 , carrying interest rate of 8.1% per annum (March 31, 2022: Rs 2010000) against the sanctioned auto loan amount of Rs 2010000 (March 31, 2022:Rs 2010000) from HDFC Bank. The current outstanding amount against the loan is Rs 1039076.35 (March 31, 2022: Rs 1427864.48).The loan was obtained for the purpose of purchasing MG Hectar electric vehicle by the company during the financial year 20-21 .The term loan is repayable in 60 equated monthly instalments commencing from 5th August , 2020. This term loan is secured by way of hypothecation over the Company's electronic vehicle for which the loan is obtained.
- (b) The company has availed secured auto loan of Rs 381800 , carrying interest rate of 11.50 % per annum (March 31, 2022: Rs 381800) against the sanctioned auto loan amount of Rs 381800 (March 31, 2022:Rs 381800) from Kotak Mahindra Bank. The loan has been fully paid during the year (March 31, 2022: Rs 12469).The loan was obtained for the purpose of purchasing Maruti EECO CNG Van by the company during the financial year 19-20 .The term loan was repayable in 36 equated monthly instalments commencing from 1st May , 2019. This term loan is secured by way of hypothecation over the Company's Maruti EECO Van for which the loan is obtained.
- (c) The company has availed secured machinery loan of Rs 6000000 , carrying interest rate of 6% per annum (March 31, 2022: Rs 0) against the sanctioned machinery loan amount of Rs 6100000 (March 31, 2022:Rs 0) from SIDBI. The current outstanding amount against the loan is Rs 6000000.00 (March 31, 2022: Rs 0).The loan was obtained for the purpose of purchasing machinery by the company during the financial year 22-23 .The term loan is repayable in 36 equated monthly instalments commencing from May, 2024. This term loan is secured by way of hypothecation over the Company's machinery.
- (d) The company has availed secured machinery loan of Rs 12000000 , carrying interest rate of 8.27 % per annum (March 31, 2022: Rs 12000000) against the sanctioned machinery loan amount of Rs 12000000 (March 31, 2022:Rs 12000000) from SIDBI. The current outstanding amount against the loan is Rs 2898000.00 (March 31, 2022: Rs 5562000).The loan was obtained for the purpose of importing machinery by the company during the financial year 18-19 .The term loan is repayable in 54 equated monthly instalments commencing from September, 2019. This term loan was secured by way of hypothecation over the Company's machinery
- (e) The company has availed secured machinery loan of Rs 10000000 , carrying interest rate of 9.35 % per annum (March 31, 2022: Rs 10000000) against the sanctioned machinery loan amount of Rs 10000000 (March 31, 2022:Rs 10000000) from SIDBI. The current outstanding amount against the loan is Rs 2560000.00 (March 31, 2022: Rs 4792000).The loan was obtained for the purpose of purchasing machinery by the company during the financial year 18-19 .The term loan is repayable in 54 equated monthly instalments commencing from October, 2019. This term loan was secured by way of hypothecation over the Company's machinery
- (f) The company has availed secured machinery loan of Rs 13400000 , carrying interest rate of 8.35 % per annum (March 31, 2022: Rs 0) against the sanctioned machinery loan amount of Rs 13400000 (March 31, 2022:Rs 13400000) from SIDBI. The current outstanding amount against the loan is Rs 12155000.00 (March 31, 2022: Rs 0).The loan was obtained for the purpose of purchasing machinery by the company during the financial year 21-22.The term loan is





repayable in 54 equated monthly instalments commencing from November, 2022. This term loan was secured by way of hypothecation over the Company's machinery

- (g) Loans from director Mr. Sanjay Mathur of Rs. 15650000 carries an interest rate of 8 % (31st March, 2022 - 6%) per annum (March 31, 2022: Rs. 15650000.00). The current outstanding amount is Rs. 15650000 (March 31, 2022 : Rs. 15650000 The loan was taken gradually till September 2016, thereafter has stayed constant till date. The loan is repayable on demand which the company expects shall not be made within 12 months from the reporting date.
- (h) Loans from director Mrs. Archana Mathur of Rs. 10850000 carries an interest rate of 8 % (31st march, 2022 - 6%) per annum (March 31, 2022: Rs. 10850000.00). The current outstanding amount is Rs. 10850000 (March 31, 2022 : Rs. 10850000 The loan was taken gradually till September 2016, thereafter has stayed constant till date. The loan is repayable on demand which the company expects shall not be made within 12 months from the reporting date.
- (h) As on the Balance sheet date there is no default in repayment of loans and interest thereon.

	<b>Annual Repayment Schedule</b>				
	<b>23-24</b>	<b>24-25</b>	<b>24-25</b>	<b>25-26</b>	<b>26-27</b>
Term Loans from banks	8,308.32	5,869.84	5,100.92	4,980.00	393.00

- (j) The term loans are secured collaterally by Land at 335-P, Sector 46, Faridabad and by the personal guarantee of promoters to the tune of Rs. 40555000.00 (March 31, 2021 Rs. 20000000.00.)
- (k) The borrowings obtained by the company from banks and financial institutions have been applied for the purposes for which such loans were taken. In respect of the term loans which were taken in the previous year, those were applied in the respective year for the purpose for which the loans were obtained.
- There are no charges which are yet to be registered with the Registrar of Companies beyond the statutory period.

- (l) However, satisfaction for the following unexisting charges as on date has not been filed by the company on MCA site till date:

	<b>Charge ID</b>	<b>Charge Name</b>	<b>Holder</b>	<b>Date of creation</b>	<b>Charge Amount (Rs. '000)</b>	<b>Reason for non filing</b>
1	10230441	Electronica Finance Ltd.		06-07-2010	1003.49	NOC not obtained from concerned bank / institution
2	10224224	SIDBI		29-04-2010	1225.38	NOC not obtained from concerned bank / institution

## 6 **DEFERRED TAX ASSETS / LIABILITIES (NET)**

### **Deferred Tax Liabilities**

Excess of Depreciation allowance under Income Tax Law

over the depreciation provided in the books. 8,330.74 6,552.84

### **Deferred Tax Assets**

Expenses Deductible on cash basis (DTA not recognised on gratuity provision which is allowable as expense on payment basis) 0.00 0.00

Net deferred tax liability **8,330.74** **6,552.84**

## 7 **OTHER LONG TERM LIABILITIES**

Others : Security Deposits 400.00 1,000.00



		<b>400.00</b>	<b>1,000.00</b>
<b>8</b>	<b><u>LONG TERM PROVISIONS</u></b>		
	Provision for Employee Benefits - Gratuity	2,770.77	2,268.43
		<b>2,770.77</b>	<b>2,268.43</b>

**Note:-** The provision for gratuity is stated as per the estimate of the management on accrual basis. The same is not stated at an actuarial valuation in the books of accounts.

**9** **SHORT TERM BORROWINGS**

**Secured**

From banks : Overdraft Limit	0.00	0.00
Current Maturities of Long Term Borrowings - Term loans (refer note 5(a))	8,308.32	5,297.26
	<b>8,308.32</b>	<b>5,297.26</b>

**Notes:-**

- (a) Overdraft facility from HDFC Bank is secured by Equitable mortgage charge over the Industrial Property at A10, Nehru Ground, NIT, Faridabad. It is also secured by personal guarantee of the promoters. The facility is repayable on demand and carry interest at 2.25% above the bank's MCLR that makes it ranging between 10.10% to 11.50%
- (b) As on the Balance sheet date there is no default in repayment of loans and interest thereon.

**10** **TRADE PAYABLES**

Total Outstanding dues of MSMEs	13,769.12	2,380.91
Total Outstanding dues of creditors other than MSMEs	99,270.06	90,914.50
	<b>113,039.18</b>	<b>93,295.41</b>

**Trade payables ageing schedule as at 31 March 2023**

Outstanding for following periods from due date of payment						
	Particulars	Less than 1 year	1-2 years	2-3 years	More than 3 years	Total
(i)	MSME	13,769.12	-	-	-	13,769.12
(ii)	Others	97,926.60	25.64	139.68	806.20	98,898.12
(iii)	Disputed dues - MSME	-	-	-	-	-
(iv)	Disputed dues - Others	-	-	-	371.94	371.94
	<b>Total</b>	<b>111695.72</b>	<b>25.64</b>	<b>139.68</b>	<b>1178.14</b>	<b>113039.18</b>

**Trade payables ageing schedule as at 31 March 2022**

Outstanding for following periods from due date of payment						
	Particulars	Less than 1 year	1-2 years	2-3 years	More than 3 years	Total
(i)	MSME	2,380.91	-	-	-	<b>2380.91</b>
(ii)	Others	60,767.52	27,153.59	1,881.65	790.58	<b>90593.34</b>
(iii)	Disputed dues - MSME	-	-	-	-	-
(iv)	Disputed dues - Others	-	-	321.15	-	<b>321.15</b>



<b>Total</b>	<b>63,148.44</b>	<b>27,153.59</b>	<b>2,202.80</b>	<b>790.58</b>	<b>93295.41</b>
--------------	------------------	------------------	-----------------	---------------	-----------------

**Notes:-**

- (i) Trade Payables include due to related parties Rs 0.00 Thousands (March 31, 2022 : Rs. 581.42 Thousands ) {refer note 31(c)}
- (ii) The amounts are unsecured and non interest-bearing and are usually on varying trade term.
- a) The information as required to be disclosed under The Micro, Small and Medium Enterprises Development Act, 2006 ("the act") has been determined to the extent such have been identified by the company, on the basis of information and records available with them. This information has been relied upon by the Auditors.

**Particulars**

I	Principal amount remaining unpaid as at end of the period	13,769.12	2,380.91
II	Interest due on above	<u>1,075.16</u>	<u>0.00</u>
1	Total of I & II	14,844.28	2,380.91
2	The amount of interest paid by the buyer in terms of section 16, of the MSMED Act, 2006 along with the amounts of the payment made to the supplier beyond the appointed day during each accounting year.	0.00	0.00
3	The amount of interest due and payable for the period of delay in making payment (which have been paid but beyond the appointed day during the year) but without adding the interest specified under MSMED Act, 2006	1,075.16	0.00
4	The amount of interest accrued and remaining unpaid at the end of each accounting year.	1,075.16	0.00
5	The amount of further interest remaining due and payable even in the succeeding years, until such date when the interest dues as above are actually paid to the small enterprise for the purpose of disallowance as a deductible expenditure under section 23 of the MSMED Act, 2006	1,075.16	0.00
11	<b><u>OTHER CURRENT LIABILITIES</u></b>		-
	Interest Accrued but not due on borrowings	1,868.00	2,839.75
	<b>Other Payables</b>		
	Statutory Dues	570.55	917.68
	Employee Related Liabilities	5,845.26	3,436.16
	Other provisions	2,100.08	2,117.11
	Advance from Customers	<u>336.97</u>	<u>163.42</u>
		<b><u>10,720.86</u></b>	<b><u>9,474.12</u></b>

**Notes:**

- i) Interest accrued but not due on borrowings represent the interest amount on unsecured loans given by the directors of the company. {Refer Note 5(b)}

**12 SHORT TERM PROVISIONS**

**Others**

Dividend Payable	1.20	1.20
Provision of Income Tax (Net of Advance Tax)	-	<u>847.64</u>
	<b><u>1.20</u></b>	<b><u>848.84</u></b>



(Amount in Rs. Thousands)

SCHEDULE OF PROPERTY, PLANT AND EQUIPMENT ATTACHED TO AND FORMING PART OF THE BALANCE SHEET AS AT 31ST MARCH, 2023											
S. No.	DESCRIPTION	GROSS BLOCK				DEPRECIATION				NET BLOCK	
		AS AT 01.04.22	ADDITION (S) DURING THE PERIOD	SALES/ADJUSTMENTS	AS AT 31-03-2023	AS AT 31.3.22	FOR THE PERIOD	SALES/ADJUSTMENTS	AS AT 31.03.23	AS AT 31.03.23	AS AT 31.03.22
1	TANGIBLE ASSETS										
	LAND	27,673.11	0.00	0.00	27,673.11	0.00	0.00	0.00	0.00	27,673.11	27,673.11
2	BUILDING	23,208.75	1,090.97	0.00	24,299.72	3,832.67	780.07	0.00	4,612.74	19,686.98	19,376.08
3	PLANT & MACHINERY (MAIN)	61,811.85	22,404.66	0.00	84,216.51	22,254.39	5,379.43	0.00	27,633.81	56,582.70	39,557.46
4	FURNITURE & FIXTURE	2,838.17	125.33	0.00	2,963.50	814.02	299.13	0.00	1,113.15	1,850.34	2,024.14
5	VEHICLES	3,764.62	4,500.00	0.00	13,264.62	5,537.97	734.02	0.00	6,271.99	6,992.62	3,226.65
6	OFFICE EQUIPMENT	1,473.11	313.77	0.00	1,786.88	699.88	363.88	0.00	1,063.76	723.12	773.23
	OTHERS:										
7	COMPUTER	2,123.91	288.43	0.00	2,412.34	1,311.91	491.31	0.00	1,803.22	609.12	812.00
8	ELECTRICAL FITTING	1,900.60	0.00	0.00	1,900.60	549.80	136.70	0.00	686.50	1,214.11	1,350.80
9	MOBILE PHONE	178.65	67.71	0.00	246.36	129.61	23.88	0.00	153.49	92.87	49.03
10	PLANT & MACHINERY (OTHER)	13,375.64	2,600.69	0.00	15,976.32	2,874.22	1,007.37	0.00	3,881.59	12,094.74	10,501.42
	<b>TOTAL</b>	<b>143,348.39</b>	<b>31,391.57</b>	<b>0.00</b>	<b>174,739.96</b>	<b>38,004.47</b>	<b>9,215.77</b>	<b>0.00</b>	<b>47,220.24</b>	<b>127,519.72</b>	<b>105,343.92</b>
	<b>Previous Year</b>	<b>136,135.45</b>	<b>7,212.94</b>	<b>0.00</b>	<b>143,348.39</b>	<b>31,426.12</b>	<b>6,578.35</b>	<b>0.00</b>	<b>38,004.47</b>	<b>105,343.92</b>	<b>104,709.33</b>

**Notes:-**

(i) Plant and machinery, generators, furniture and fixtures, electric fans and installations has been pledged/hypothecated as security to the company.

(ii) There are no projects under Capital Work in progress as at year end. (March 31, 2022 : Nil)

(iii) There are no Immovable Properties that are not held in name of the Company as at year end. (March 31 2022: Nil)

(iv) There are no projects under Intangible assets under development as at year end. (March 31, 2022 : Nil)

**14 OTHER NON CURRENT ASSETS****Unsecured, considered good**

Capital Advances	66.60	66.60
Security Deposits	3,583.26	3,183.84
<b>Others (Unsecured, considered good)</b>		
Rent Receivable - Pune Godown	154.80	154.80
	<b>3,804.66</b>	<b>3,405.24</b>

**Note:-**

i) Rent receivable belongs to the period Oct and Nov, 2016 and is to be received from M/s Shilpi Cable Technologies Limited.

The above company is under liquidation and its creditors are being handled by NCLT. Our company awaits the final orders of NCLT before taking any action on the said amount.



The amount is considered good because the company already has a security deposit from the liquidated company.

**15 INVENTORIES**

**(Valued at lower of cost and net realisable value unless otherwise stated)**

Raw Material	8,922.93	12,568.91
WIP	0.00	0.00
Finished Goods	9,839.88	11,368.37
Consumables	<u>265.86</u>	<u>163.80</u>
	<b><u>19,028.67</u></b>	<b><u>24,101.08</u></b>

**i) Notes: -**

Inventories are hypothecated with the bankers against working capital limits.

**16 TRADE RECEIVABLES**

Unsecured, considered good unless stated otherwise	<u>181,193.77</u>	<u>142,784.94</u>
--	-------------------	-------------------

**(I) Trade receivables ageing schedule as at 31 March 2023**

Outstanding for following periods from due date of payment							
	Particulars	Less than 6 months	6 months - 1 year	1 - 2 years	2 - 3 years	More than 3 years	Total
(i)	Undisputed Trade receivables - considered good	138115.37	32642.36	450.06	1372.45	180.95	172761.20
(ii)	Undisputed Trade receivables - considered doubtful	-	-	-	-	3.25	3.25
(iii)	Disputed Trade receivables - considered good	-	-	-	-	8,429.33	8,429.33
(iv)	Disputed Trade receivables - considered doubtful	-	-	-	-	-	-
	<b>Total</b>	<b>138115.37</b>	<b>32642.36</b>	<b>450.06</b>	<b>1372.45</b>	<b>8613.53</b>	<b>181193.77</b>
	Less: Allowance for bad and doubtful debts	0.00	0.00	0.00	0.00	0.00	0.00
	<b>Total</b>	<b>138115.37</b>	<b>32642.36</b>	<b>450.06</b>	<b>1372.45</b>	<b>8613.53</b>	<b>181193.77</b>

**(II) Trade receivables ageing schedule as at 31 March 2022**

Outstanding for following periods from due date of payment							
	Particulars	Less than 6 months	6 months - 1 year	1 - 2 years	2 - 3 years	More than 3 years	Total
(i)	Undisputed Trade receivables - considered good	128248.22	3670.66	1448.17	333.58	0.00	133,700.63
(ii)	Undisputed Trade receivables - considered doubtful	-	-	365.56	35.23	96.73	497.52
(iii)	Disputed Trade receivables - considered good	-	-	-	1,884.01	6,702.78	8,586.79





(iv)	Disputed Trade receivables considered doubtful	-	-	-	-	-	-
	<b>Total</b>	<b>128,248.22</b>	<b>3,670.66</b>	<b>1,813.73</b>	<b>2,252.82</b>	<b>6,799.51</b>	<b>142784.94</b>
	Less: Allowance for bad and doubtful debts	0.00	0.00	0.00	0.00	0.00	0.00
	<b>Total</b>	<b>128248.22</b>	<b>3670.66</b>	<b>1813.73</b>	<b>2252.82</b>	<b>6799.51</b>	<b>142784.94</b>

**Note**

**s:-**

- (a) Trade receivables are usually on trade terms based on credit worthiness of customers as per the terms of contract with customers.
- (b) Neither trade nor other receivables are due from directors or other officers of the company either severally or jointly with any other person, nor any trade or other receivables are due from firms or private companies respectively in which any director is a partner, a director or a member.

**17 CASH AND CASH EQUIVALENTS**

(a) Balances with Bank		
Current Accounts	145.77	129.61
Over Draft Accounts	4,876.79	6,394.67
Unpaid dividend account	1.20	1.20
(b) Cash on hand	348.05	204.84
	<u><b>5,371.80</b></u>	<u><b>6,730.32</b></u>

**Notes:**

- (a) There are no restrictions with regard to cash and cash equivalents as at the end of the reporting period and prior period except as on unpaid dividend account which can't be used by the company.

<b>18</b>	<b><u>SHORT TERM LOANS &amp; ADVANCES</u></b>	<b><u>As At 31-03-2023</u></b>	<b><u>As At 31-03-2022</u></b>
	<b><u>Unsecured, Considered good</u></b>		
	<b>Loans &amp; Advances</b>		
	Advances to Materials and Services	5517.49	10254.58
	Advances to Staff	363.29	16.94
	<b>Others</b>		
	Prepaid Insurance / Expenses	393.91	218.66
	Balance with Government Authorities	5789.65	2,494.64
		<u><b>12,064.35</b></u>	<u><b>12,984.82</b></u>

**Notes:-**

- (a) Loans and advances does not include any amount that is due from directors or other officers of the company either severally or jointly with any other person, nor are they due from firms or private companies respectively in which any director is a partner, a director or a member.

**19 OTHER CURRENT ASSETS**

**BANK BALANCE OTHER THAN CASH & CASH EQUIVALENTS**

Fixed Deposits	10,184.74	6,884.38
	<u><b>10,184.74</b></u>	<u><b>6,884.38</b></u>

**(Amount In Rs.Thousands)**

**As At 31-03-2023      As At 31-03-2022**

**20 Revenue From Operations**

- (a) Sale of products      443,345.00      294,586.66



(b)	Sale of services	0.00	0.00
	<b>Total</b>	<b>443,345.00</b>	<b>294,586.66</b>
(i)	<b>Disaggregation of revenue based on product or service</b>		
	- Wipers	112,384.32	52,771.11
	- Couplers	313,385.43	233,615.38
	- Blade Fuse	14,395.22	5,573.68
	- Scrap	3,180.03	2,626.49
		443,345.00	294,586.66
<b>21</b>	<b><u>OTHER INCOME</u></b>		
	<b>Interest Received on</b>		
	- Deposit with Banks	472.38	157.35
	- Others - on overdue bills from customers	0.00	452.11
	<b>Other non-operating income</b>		
	Rent Received	242.00	1,419.00
	Gain on Foreign Exchange Fluctuation	328.89	0.00
	Miscellaneous Income	0.40	15.56
		<b>1,043.67</b>	<b>2,044.02</b>
<b>22</b>	<b><u>COSTS OF MATERIAL CONSUMED</u></b>		
a)	<b>RAW MATERIAL CONSUMED</b>		
	Opening Stock	12,568.91	7,771.44
	Add: Cost of purchases of raw material	281,301.09	196,143.10
	Less: Closing Stock	8,922.93	12,568.91
	<b>Total</b>	<b>284,947.07</b>	<b>191,345.63</b>
(i)	<b>Disaggregation of Raw Material</b>		
	Plastic Granules & Master Batch	177,281.14	137,832.95
	Master Batch	1,244.19	910.77
	Rubber Seal	4,251.55	3,099.11
	Rejection recd.	-5,927.71	1,253.31
	Consumable stores	1,703.74	2,681.87
	Packing Material	26,956.33	13,017.31
	Terminals & U Clips, SS components	950.32	816.54
	CRC coil	33,167.34	18,371.44
	Zinc Strip	1,782.42	3,643.82
	Brass coil	7,076.08	1,917.23
	Rivets	4,962.95	909.98
	Rubber (for wiper)	20,025.69	11,688.77
	Stainless Steel Wire	7,827.05	-
		<b>281,301.09</b>	<b>196,143.10</b>
<b>22A</b>	<b><u>Inventories at the end of the period</u></b>		
	Finished Goods	9,839.88	11,368.37
	Consumables	265.86	163.80
		<b>10,105.74</b>	<b>11,532.17</b>
	<b><u>Inventories at the beginning of the period</u></b>		
	Finished Goods	11,368.37	8,492.37
	Consumables	163.80	137.80
		<b>11,532.17</b>	<b>8,630.17</b>
	<b>Net Increase/ Decrease</b>	<b>1,426.43</b>	<b>-2,902.00</b>



<b>23</b>	<b><u>EMPLOYEE BENEFITS EXPENSE</u></b>		
	Salaries, wages, bonus and other benefits	42,174.78	29,818.56
	Gratuity expense {refer note 29 }	696.64	440.20
	Contribution to Provident Fund	1,905.54	1,371.43
	Employee State Insurance Welfare Fund	486.49	253.98
		84.15	26.59
	Staff Welfare Expenses	965.18	699.25
	<b>Total</b>	<b><u>46,312.78</u></b>	<b><u>32,610.01</u></b>
<b>24</b>	<b><u>FINANCE COST</u></b>		
	Interest on CC Limit	18.75	18.30
	Interest on Term loans	1,636.28	1,290.74
	Interest on late payment to MSME	1,075.16	0.00
	Interest on Unsecured Loans	2,120.00	1,590.00
	<b>Total</b>	<b><u>4,850.19</u></b>	<b><u>2,899.04</u></b>
<b>25</b>	<b><u>DEPRECIATION AND AMORTISATION EXPENSE</u></b>		
	Depreciation of property, plant and equipment {refer note 13}	9,215.77	6,578.35
	<b>Total</b>	<b><u>9,215.77</u></b>	<b><u>6,578.35</u></b>
<b>26</b>	<b><u>OTHER EXPENSES</u></b>		
	Advertisement & Publicity Expenses	3,599.26	2,605.13
	Bank Charges	128.91	259.22
	Bad Debts & Discount	1,039.67	15.34
	Consumable Stores	53.82	58.64
	Conveyance Expenses	721.23	446.42
	Festival Celebration Expenses	526.50	292.26
	Donation	12.50	7.50
	Power & Fuel	18,319.19	14,928.74
	Fluctuation in Exchange Rates	0.00	142.39
	Clearing and Forwarding Charges	462.17	0.00
	Freight & Cartage	6,894.90	3,594.58
	Insurance Expenses	3,469.46	3,118.18
	Labour Contract Works / Job Work Charges	15,080.55	11,174.18
	Packing Charges	20.90	25.73
	Miscellaneous Expenses	659.22	573.88
	Office Expenses	120.02	0.00
	Printing & Stationery Exp.	512.86	351.98
	Professional & Legal Fee	1,531.87	1,619.00
	Rates, Fees & Taxes	212.01	259.97
	Rent Paid	680.00	0.00
	Repair & Maintenance		
	- To Building	1,353.02	251.54
	- To Plant, Machinery and other Equipment	10,447.32	4,506.77
	Security and Safety	1,055.72	1,253.60



Expenses		
Telephone & Internet Expenses	247.72	220.11
Training Expenses	0.00	0.00
Travelling & Tour Expenses	19.32	303.70
Payment to Auditors	247.50	445.50
<b>Total</b>	<b>67,415.63</b>	<b>46,454.35</b>

**EARNINGS PER SHARE (EPS)**

27	Net Profit after Tax (In Rupees' 000 )	22,252.15	15,030.17
a)	(Numerator used for calculation)		
b)	Weighted Average number of Equity Shares (Denominator used for calculation)	5,203,571.00	5,203,571.00
c)	Basic & Diluted Earning per Share of Rs. 10/- each (In Rupee)	4.28	2.89

**COMMITMENTS & CONTINGENCIES**

28	<b>A</b>	<b>Contingent liabilities (to the extent not provided for)</b>	<b>As At March 31,2023</b>	<b>(Rs. in '000) As At March 31,2022</b>
----	----------	--	----------------------------	--

A	Claims / Suits filed against the Company not acknowledged as debts ( Refer point (i))		
B	Disputed tax liabilities in respect of pending litigations before appellate authorities {Amount deposited under protest Rs 0.00 (March 31, 2022: Rs. 0.00, included in "deposit with statutory and government authorities" in note no. {refer point (ii)}	0.00	0.00

**Note**

s:

- i) There were no claims / suits filed against the Company during the year.  
ii) The various disputed tax litigations are as under :

Sl.	Description { refer note below }	Period to which relates (Assessment Year)	Disputed demand amount At March 31,2023	Disputed demand amount As At March 31,2022
a)	<b><u>Income Tax</u></b> Assessed at wrong rate of tax by the assessing officer, appeal pending at CIT(A) level	2018-19	1675.78	1539.66
			<b>1675.78</b>	<b>1539.66</b>

Notes:

"The Company is contesting these demands and the management, believe that its position will likely to be upheld in the appellate process and accordingly no provision has been accrued in the financial statements for these tax demand raised. The management believes that the ultimate outcome of this proceeding will not have a material adverse effect on the Company's financial position and results of operations.

The Company does not expect any liability against these matters."

The above amounts contain interest and penalty where included in the order issued by the department to the Company

B	<b>Commitments</b>	<b>As At March 31,2023</b>	<b>(Rs. in '000) As At March 31,2022</b>
---	--------------------	----------------------------	--



Estimated amount of capital contracts remaining to be executed and not provided for (Net of Advances amounting to Rs (March 31, 2022: Rs ))

- -

- -

## 29 Post-employment benefit plans - Gratuity

The provision for gratuity is stated at an estimate of liability by the management and has not been valued by an actuary.

	(Rs. in '000)	
	As At March 31,2023	As At March 31,2022
a) <b>Reconciliation of opening and closing balances of Defined Benefit obligation</b>		
Provision for gratuity at the beginning of the year	2268.43	2103.61
Add: Estimated provision for gratuity for the current period	696.64	440.20
Less: Benefit Paid	-194.30	-275.38
Provision for gratuity at the end of the year	2770.77	2268.43

	(Rs. in '000)	
	As At March 31,2023	As At March 31,2022
30 <b>Expenditure / Income in Foreign Currency (INR)</b>		
<b>Value of Imports on CIF basis (INR)</b>		
1. Raw Material	16,094.53	13,347.82
2. Components and Spare Parts	0.00	0.00
3. Capital Goods	14,102.48	0.00
<b>Earnings in Foreign Currency (INR)</b>		
1. Export of goods calculated on FOB basis	0.00	0.00

## 31 RELATED PARTY DISCLOSURES

The related parties as per the terms of AS-18,"Related Party Disclosures", { under the section 133 of the Companies Act 2013 (the Act) read with Companies (Indian Accounting Standards) Rules 2015 (as amended from time to time)}, as disclosed below:-

### (A) **Names of related parties and description of relationship :**

#### a) **Key Management Personnel**

Mr. Sanjay Mathur	Managing Director
Mrs. Archana Mathur	Director
Mr. Aditya Mathur	Director
Mr. Prabhat Bhatia	CFO
Ms. Sarita Chaurasia	Company Secretary

#### b) **Relatives of Key Management Personnel**

Vaibhav Mathur	Son of Managing Director
Parul Mathur	Daughter of Managing Director

#### c) **Enterprises in which directors are interested**

Ultra Auto Components Prop. Mrs. Archana Mathur
Ultra Harness Industries Prop. Sanjay Mathur

### (B) **Transactions carried out during the year**

Nature of Transactions	(Rs. in '000)	
	As At March 31,2023	As At March 31,2022
<b>Purchases</b>		
-Ultra Harness Industries Prop. Sanjay Mathur		





Raw Material	0.00	0.00
Capital Goods	0.00	0.00
<b>Expenses</b>		
<b>Managerial Remuneration</b>		
<b>Key Management Personnel</b>	8,886.52	9,149.12
Salaries, wages, bonus, commission and other benefits		
Contribution towards PF, Family Pension and ESI		
Post-employment benefits		
<b>Remuneration</b>		
<b>Relative of Key Management Personnel</b>	1,760.40	1,134.60
Salaries, wages, bonus, commission and other benefits		
Contribution towards PF, Family Pension and ESI		
Post-employment benefits		
<b>Interest on Unsecured loan</b>		
Mr. Sanjay Mathur	1,252.00	939.00
Mrs. Archana Mathur	868.00	651.00
<b>(C)</b>		
<b>i)</b>		
<b>Balances at year end</b>		
Amount Payables		
<b>Unsecured Loans taken</b>		
<b>Key Management Personnel</b>	26,500.00	26,500.00
<b>Trade Payables</b>		
<b>Enterprises in which directors are interested</b>		
Ultra Auto Components Prop. Mrs. Archana Mathur	0.00	0.00
Ultra Harness Industries Prop. Sanjay Mathur	0.00	581.42
<b>Expenses Payables</b>		
<b>Key Management Personnel</b>	2,688.01	3,279.75
<b>Relative of Key Management Personnel</b>	213.57	123.00

32 The Company has not been declared as a Wilful Defaulter by any bank or financial institution or government or any government authority.

### 33 Analytical ratio

Ratio	Numerator		Denominator		As at 31 March, 2023	As at 31 March, 2022	Change	Explanation for change in the ratio by more than 25% as compared to the previous year
	March 31, 2023	March 31, 2022	March 31, 2023	March 31, 2022				
(a) Current Ratio (times) = Current assets/ Current liabilities	March 31, 2023	227,843.32	March 31, 2023	132,069.56	1.73	1.78	- 2.89%	Not Applicable
	March 31, 2022	193,485.54	March 31, 2022	108,915.63				
(b) Debt-Equity Ratio (times) = Total Borrowings/ Shareholder's equity	March 31, 2023	51,152.08	March 31, 2023	172,752.87	0.30	0.25	16.37 %	Not Applicable
	March 31, 2022	38,294.33	March 31, 2022	150,500.72				



(c) Debt Service Coverage Ratio = Earnings available for debt service/ Debt service {refer note i}	March 31,2023	44,286.75	March 31,2023	10,147.45	4.36	3.42	27.79 %	Earnings have increased while instalment repayment has not begun for one big term loan during the year.
	March 31,2022	29,122.68	March 31,2022	8,527.11				
(d) Return on Equity Ratio % = Net Profits after taxes/ Average shareholder's equity	March 31,2023	22,252.15	March 31,2023	161,626.79	13.77%	10.51%	30.97 %	Increase in Net Profits
	March 31,2022	15,030.17	March 31,2022	142,985.64				
(e) Inventory turnover ratio (times) = Revenue from operations/ Average inventory	March 31,2023	443,345.00	March 31,2023	21,564.88	20.56	14.55	41.33 %	Increase in Turnover
	March 31,2022	294,586.66	March 31,2022	20,251.35				
(f) Trade receivables turnover ratio (times) = Net credit revenue from operations/ Average trade receivables	March 31,2023	443,345.00	March 31,2023	161,989.35	2.74	2.14	27.84 %	The company has improved its collection process
	March 31,2022	294,586.66	March 31,2022	137,606.96				
(g) Trade payables turnover ratio (times) = Net credit purchases/ Average trade payables	March 31,2023	281,301.09	March 31,2023	103,167.30	2.73	2.19	24.68 %	Not Applicable
	March 31,2022	196,143.10	March 31,2022	89,690.03				
(h) Net capital turnover ratio (times) = Revenue from operations/ Working capital	March 31,2023	443,345.00	March 31,2023	95,773.77	4.63	3.48	32.89 %	Increase in Turnover
	March 31,2022	294,586.66	March 31,2022	84,569.91				
(i) Net profit ratio % = Net profit/ Revenue from operations	March 31,2023	22,252.15	March 31,2023	443,345.00	5.02%	5.10%	- 1.63%	Not Applicable
	March 31,2022	15,030.17	March 31,2022	294,586.66				
(j) Return on capital employed % = EBIT/ Capital employed {refer note ii}	March 31,2023	35,070.98	March 31,2023	232,235.68	15.10%	11.54%	30.86 %	Increase in net profits
	March 31,2022	22,544.33	March 31,2022	195,347.89				
(k) Return on investment % = EBIT/ Average total assets	March 31,2023	35,070.98	March 31,2023	330,701.19	10.61%	7.67%	38.21 %	Greater increase in Net profit in absolute terms in comparison to increase in assets.
	March 31,2022	22,544.33	March 31,2022	293,807.23				

Notes:

(i) Debt service = Interest + Principal Repayments

(ii) Capital Employed = Tangible Net Worth (Total Equity Less Goodwill Less Other Intangible Assets Less Intangible Assets under Development) + Total Borrowing + Deferred Tax Liability

(iii) Tangible Network is computed as Total Assets - Total Liabilities.

**Struck off Companies: Details of relationship with Companies struck off under Section 248 of Companies Act, 2013 or Section 248 of the Companies Act, 1956: Nil**

Name of the struck off Company	Nature of transaction with struck off Company	Balance outstanding as at March 31, 2022 (Rs. '000)	Balance outstanding as at March 31, 2021 (Rs. '000)	Relation with struck off Company
Nil	Purchase of Goods	0	0	Customer



	Sales of Goods	0	0	Customer
--	----------------	---	---	----------

**35 Additional regulatory information required by Schedule III of Companies Act, 2013**

(i) **Details of Benami property:** No proceedings have been initiated or are pending against the Company for holding any Benami property under the Benami Transactions (Prohibition) Act, 1988 (45 of 1988) and the rules made thereunder.

(ii) **Utilisation of borrowed funds and share premium:**

The Company has not advanced or loaned or invested funds to any other person(s) or entity(ies), including foreign entities (Intermediaries) with the understanding that the Intermediary shall:

(a) directly or indirectly lend or invest in other persons or entities identified in any manner whatsoever by or on behalf of the Company (Ultimate Beneficiaries) or

b) provide any guarantee, security or the like to or on behalf of the ultimate beneficiaries.

The Company has not received any fund from any person(s) or entity(ies), including foreign entities (Funding Party) with the understanding (whether recorded in writing or otherwise) that the Company shall:

a) directly or indirectly lend or invest in other persons or entities identified in any manner whatsoever by or on behalf of the Funding Party (Ultimate Beneficiaries) or

b) provide any guarantee, security or the like on behalf of the ultimate beneficiaries.

(iii) **Compliance with number of layers of companies:** The Company has complied with the number of layers prescribed under the Companies Act, 2013.

(iv) **Compliance with approved scheme(s) of arrangements:** The Company has not entered into any scheme of arrangement which has an accounting impact on current or previous financial year.

(v) **Undisclosed income:** There is no income surrendered or disclosed as income during the current or previous year in the tax assessments under the Income Tax Act, 1961, that has not been recorded in the books of account.

(vi) **Details of crypto currency or virtual currency:** The Company has not traded or invested in crypto currency or virtual currency during the current or previous year.

(vii) **Valuation of PP&E, intangible asset and investment property:** The Company has not revalued its property, plant and equipment or intangible assets or both during the current or previous year.

(viii) The company has not granted any loans or advances in the nature of loans either repayable on demand.

36 The figures have been rounded off to the nearest thousands of rupees upto two decimal places. The figure 0.00 wherever stated represents value less than Rs. 100/-.

37 Borrowing Costs capitalised during the year amounts to Rs. Nil. (Previous Year - Rs. 0.00)

38 Note No.1 to 39 form integral part of the Standalone Balance Sheet and Standalone Statement of Profit and Loss.

39 Previous year figures have been re-grouped or re-arranged wherever necessary.

The accompanying notes referred to above form an integral part of the financial statements.

**As per our Report of even date**

**For and On behalf of Board of Directors**

**For SANMARKS & ASSOCIATES  
CHARTERED ACCOUNTANTS  
FRN : 003343N**

Sd/-  
**(SANJAY MATHUR)  
DIRECTOR  
DIN: 00285032**

Sd/-  
**(ARCHANA MATHUR)  
DIRECTOR  
DIN: 00285041**



**SANTOSH KUMAR AGRAWAL  
(PARTNER), M. NO. 091127**

**PLACE : FARIDABAD  
DATED : 27/05/2023**

**Sd/- Sd/-  
(PRABHAT BHATIA) (SARITA CHAURASIA)  
Chief Financial Officer Company Secretary**

**ULTRA**



18<sup>th</sup> Annual General Meeting  
**ULTRA WIRING CONNECTIVITY SYSTEM LIMITED**  
(Formerly known as Ultra Wiring Connectivity System Private Limited)

**Form No. MGT-11**

**FORM OF PROXY**

[Pursuant to Section 105(6) of the Companies Act, 2013 and Rule 19(3) of the Companies (Management and Administration) Rules, 2014]

CIN	<b><u>L31300HR2005PLC082730</u></b>
Name of the Company	ULTRA WIRING CONNECTIVITY SYSTEM LIMITED
Registered office	Plot 287, Sector 59, HSIIDC Indl Estate, Ballabgarh, Faridabad- 121004
Name of the member(s)	
Registered Address	
Email ID	
Folio ID / Client ID-DP IF	

I/We, being a member(s) of \_\_\_\_\_ shares of Ultra Wiring Connectivity System Limited hereby appoint:

1. Mr./Mrs. \_\_\_\_\_  
Address \_\_\_\_\_  
Email Id: \_\_\_\_\_  
Signature \_\_\_\_\_  
Or Failing him \_\_\_\_\_
2. Mr./Mrs. \_\_\_\_\_  
Address \_\_\_\_\_  
Email Id: \_\_\_\_\_  
Signature \_\_\_\_\_  
Or Failing him \_\_\_\_\_
3. Mr./Mrs. \_\_\_\_\_  
Address \_\_\_\_\_  
Email Id: \_\_\_\_\_  
Signature \_\_\_\_\_  
Or Failing him \_\_\_\_\_

As my/our proxy to attend and vote for me/us on my/our behalf at the 18<sup>th</sup> Annual General Meeting of the Company to be held on Saturday, September 30, 2023 at 11.30 A.M at the Registered Office of the Company at Plot 287, Sector 59. HSIIDC Indl Estate, Ballabgarh, Faridabad- 121004 and at any adjournment thereof in respect of such resolutions as are indicated below:

Resolution No.	Resolutions	Options	
		For	Against
<b>Ordinary Resolutions:</b>			
1	Adoption of Audited Annual Financial Statements		
2	Re-appointment of Mr. Sanjay Mathur, who retires by rotation		
3	To increase the remuneration of Mr. Sanjay Mathur (DIN-00285032), Managing Director of the Company		
4	To increase the remuneration of Mrs. Archana Mathur (DIN -00285041) Executive Director of the Company		

Signed this \_\_\_\_\_ day of \_\_\_\_\_ 2023 .



Affix 1  
Revenue  
Stamp



Signature of the Shareholders \_\_\_\_\_

₹

Signature of Proxy holder(s) \_\_\_\_\_

Note: This form of proxy in order to be effective should be duly completed and deposited at the Registered Office of the Company, not less than 48 hours before the commencement of the Meeting.

**ULTRA**

18<sup>th</sup> Annual General Meeting  
**ULTRA WIRING CONNECTIVITY SYSTEM LIMITED**

**ATTENDANCE SLIP**

Folio No:	DP ID:
Client ID No:	No of Shares held:

I/We record my/our presence at the 18<sup>th</sup> Annual General Meeting to be held on Saturday, September 30, 2023 at 11.30 A.M. at the Registered Office of the Company at Plot 287, Sector 59, HSIIDC Indl Estate, Ballabgarh, Faridabad- 121004.

Name of the Shareholder/Proxy (In Block letters):

Signature of the Shareholder/Proxy:

**NOTE:**

1. You are requested to sign and handover this slip at the entrance of the meeting venue.
2. Members are requested to bring their copy of Annual Report for reference at the Meeting



**THANK YOU !!**



**Ultra Wiring Connectivity System Ltd.**

**ULTRA WIRING  
SYSTEM**

**CONNECTIVITY  
(P) LTD.**

**PLOT No: 287-A & B, SECTOR-59,**

**HSIDC INDL. ESTATE BALLABGARH**

# FUSE HOLDERS

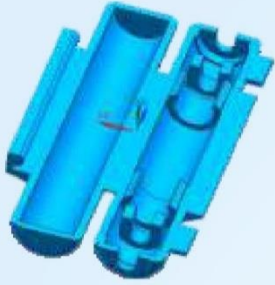

U4302-1201

1 POLE GLASS  
FUSE HOLDER

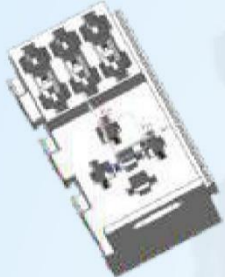

U4302-1201

HYBRID FUSE BOX  
(5 PIN RELAY +  
3 BLADE FUSES)

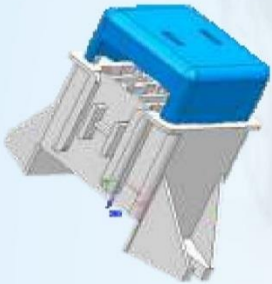

U4306-3403

U4307-3403

FUSE BOX 12 POLE  
WITH COVER

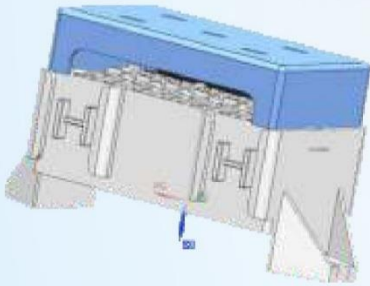

U4304-3403

U4305-3403

FUSE BOX 28 POLE  
WITH COVER

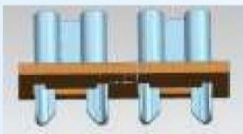

U4224-4927

FUSE CLIP WITH  
BAKELITE HOLDER

## TYPES OF PACKAGING



UVS<sup>®</sup>

# ULTRA

Blade Fuses

**ULTRA WIRING CONNECTIVITY SYSTEM LTD**

**Manufacturers of Automotive Connector & Terminal,  
Precision Plastic Components, Windshield Wiper Blades & Blade Fuses**

Plot No. 287 - A&B, Sector 59, HSIDC Industrial Estate, Ballabgarh, Faridabad, Haryana 121004 (INDIA)

M.:+91 9311360114, +91 9312327007, +91 9311360110 | E-mail: ultrafbd@gmail.com | Web: www.ultrawiring.com

